

PROX / PROPlus / PRO Series Automated Dispensing Systems Quick Start Guide

Guia Rápida • Guide Rapide de Montage • Guida rapida di avvio • Guia Rápido • Schnellstartanleitung
Průvodce rychlým nastavením • Szybki start • Краткое руководство пользователя • Gyors Beüzemelési Útmutató
快速启动指南 • クイックスタートガイド • 빠른 시작 안내서

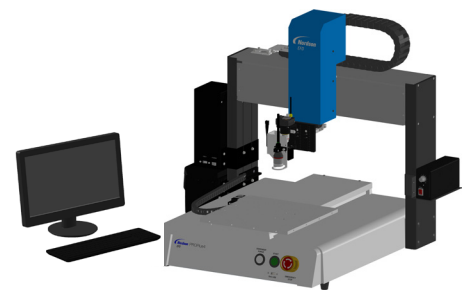

1 Unpack and Check

Desembale y Compruebe
Déballer et Vérifier
Disimballo e controllo
Desembale e verifique
Auspacken und Überprüfen
Rozbalte a zkontrolujte
Rozpakować i sprawdzić
Распакуйте и проверьте
Csomagolja ki és ellenőrizze le
開箱和检查
開梱と内容物のチェック
개봉 과 확인



2 Install DispenseMotion™ Controller

Instale el Controlador DispenseMotion
Installer le Contrôleur DispenseMotion
Installare il Controller DispenseMotion
Instale o Dispensador de Movimento Controlador
Installation DispenseMotion Controller
Nainstalujte kontrolér DispenseMotion
Instalacja DispenseMotion Controller
Установите контроллер DispenseMotion
DispenseMotion vezérlő telepítés
安装 DispenseMotion 软件控制器
DispenseMotion 컨트롤러의設置
DispenseMotion 전용 컨트롤러 설치

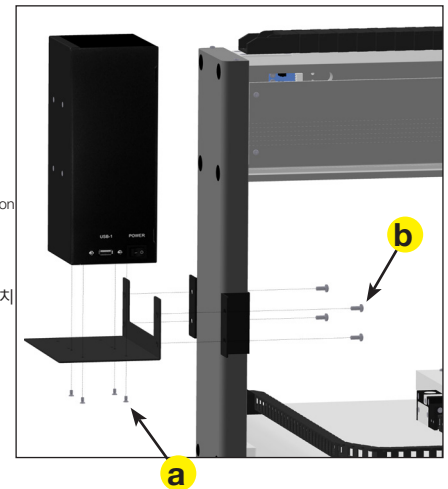

- a** M3 x 6
- b** M4 x 6

3 Install Camera

Instale Cámara
Installer la Caméra
Installa videocamera
Instale a Câmara
Kamera installieren
Nainstalujte kameru
Zainstalować kamerę
Установите камеру
Szerelje be a kamerát
安装摄像头
カメラの取り付け
카메라 설치

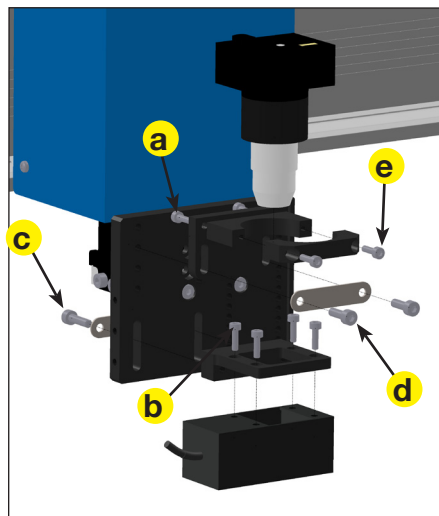

- a** M3 x 10
- b** M3 x 6
- c** M4 x 15
- d** M4 x 12
- e** M3 x 12



WATCH SETUP VIDEOS
www.nordsonefd.com/RobotInstallation

4 Install Dispensing Device

Instale el Dispositivo de Dispensación
 Installer le Système de Dosage
 Installa il dispositivo di dosatura
 Instale o Dispositivo de Dispensação
 Dosiersystem installieren
 Nainstalujte dávkovací systém
 Zainstalować system dozujący
 Установите систему дозирования
 Szerelje be az adagolóberendezést
 安装点胶设备
 塗布装置の取り付け
 디스펜싱 디바이스 설치

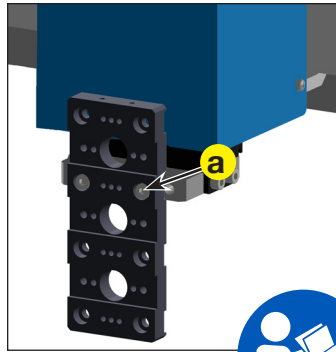

a M4 x 10

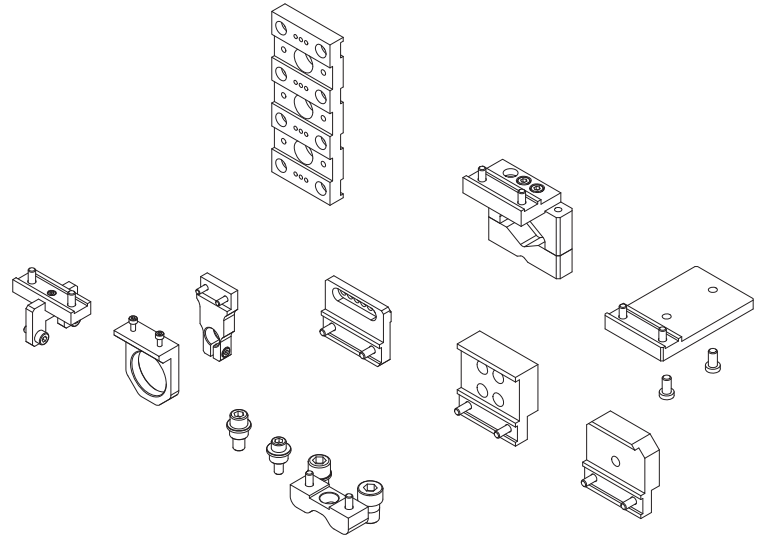

5 Install Light Controller

Instale la Lámpara de Control
 Installer le Contrôleur de Lumière
 Installa la lampada del Controller
 Instale a Lámpada de Controlo
 Lichtsteuerung installieren
 Nainstalujte Light kontrolér
 Zainstalować kontoler swiatla
 Установите контроллер
 освещения
 Szerelje be a fényforrás vezérlőjét
 安装光源控制器
 ライトコントローラの取り付け
 조명 컨트롤러 설치

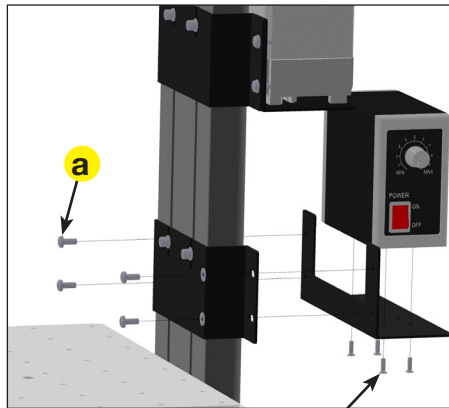

a M4 x 6

b M3 x 6

6 Connect to Camera

Conéctelo a la Cámara
 Connecter à la Caméra
 Collega a videocamera
 Conecte-o a câmara
 Kamera anschließen
 Pripojte ke kamere
 Podłączyć kamerę
 Присоедините к камере
 Csatlakoztassa a kamerát
 连接到摄像头
 カメラの接続
 카메라 연결



7 Install Laser (Optional)

Instale el Láser (Opcional)
 Installer le Laser (En option)
 Installa il Laser (Opzionale)
 Instale o Laser (Opcional)
 Laser installieren (Optional)
 Nainstalujte laser
 Zainstalować laser (Opcjonalnie)
 Установите лазер
 (дополнительная опция)
 Szerelje be a lézert (Opcionális)
 安装激光 (可选配)
 레이저의取り付け(옵션)
 레이저 설치 (옵션)

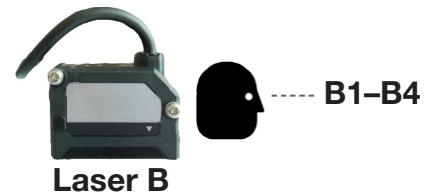

Laser B

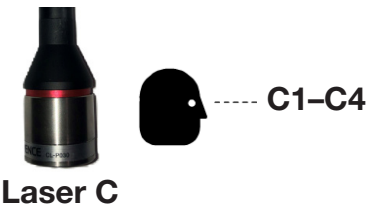

Laser C

8

Connect Cables

- Conecte Cablesde aire
- Brancher les Câbles
- Collega cavi
- Conecte os cabos
- Kabel anschließen
- Připojte kabely
- Podłączyć kabel
- Присоедините кабели
- Csatlakoztassa a kábeleket
- 连接到数据线
- ケーブルの取り付け
- 케이블 연결

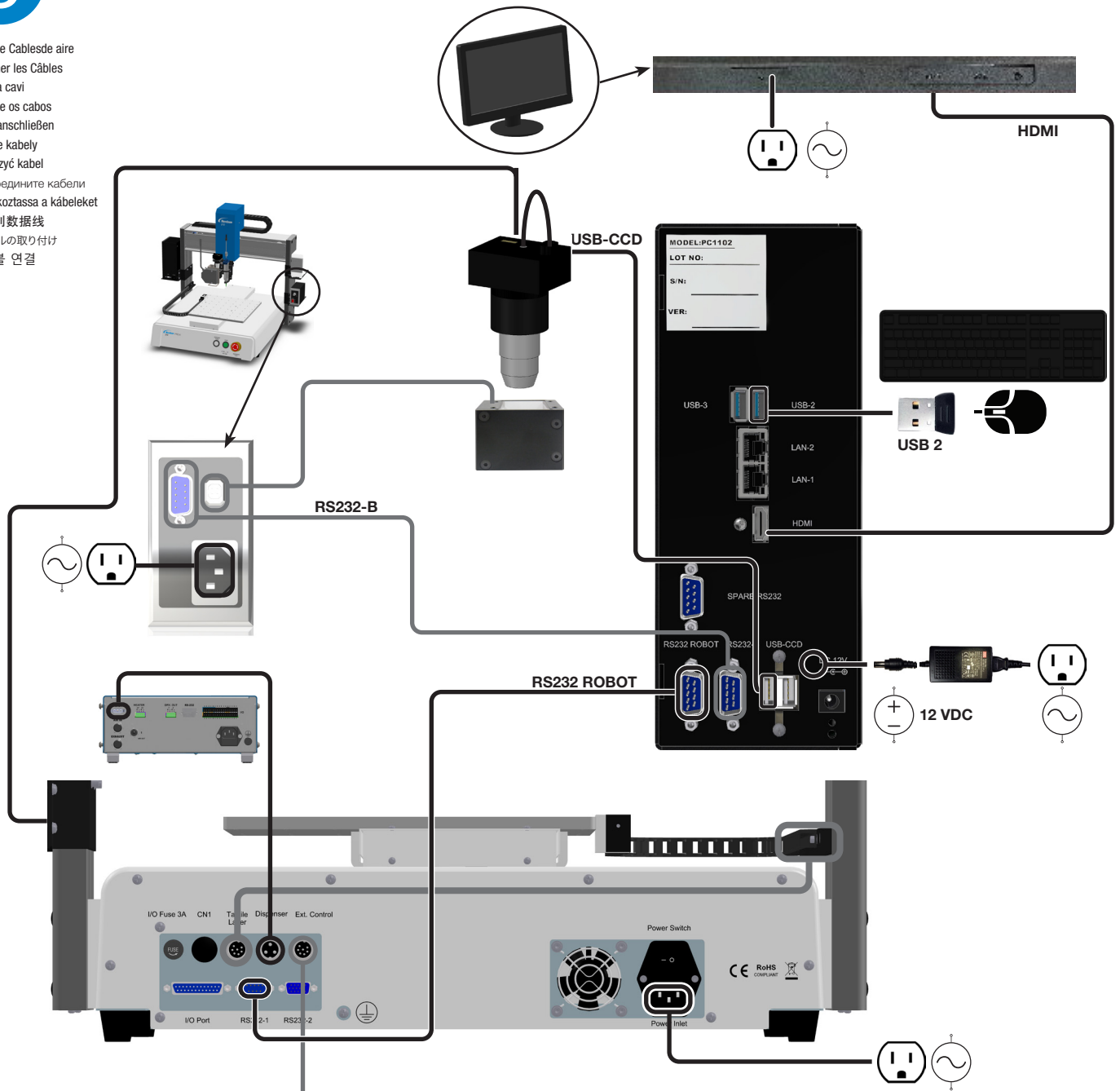

SHORTED

- Cortocircuito
- Connecteur de Sécurité
- Accorciato
- Curto Circuito
- Abgeschaltet
- Propojený
- Wyłączony
- Замкнутый контакт
- Lekapcsolt
- 短接头
- 入力/出力プラグ(短絡済み)
- 쇼트 플러그 연결

9

Power ON

- Encendido
- Alimentation ON
- Acceso
- Ligação
- Einschalten
- Zapnutí přístroje
- Włączyć
- Питание включено
- Bekarcsolás
- 电源开启
- 電源オン
- 전원 켜기

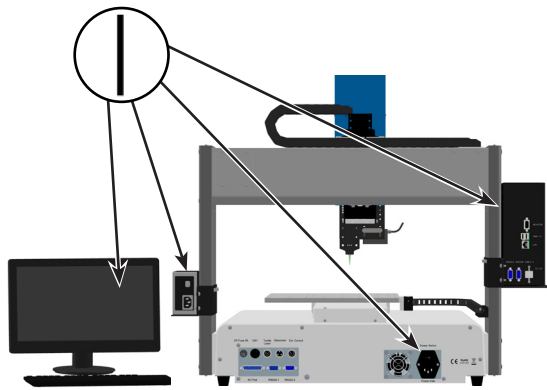

10

Open DispenseMotion

- Abrir DispenseMotion
- Ouvrir DispenseMotion
- Aprire DispenseMotion
- Abrir o Dispensador de Movimento
- DispenseMotion öffnen
- Spustte program DispenseMotion
- Otwarcie DispenseMotion
- Запустите программу DispenseMotion
- DispenseMotion megnyitás
- 启动DispenseMotion软件
- DispenseMotionソフトの立ち上げ
- DispenseMotion 프로그램 실행

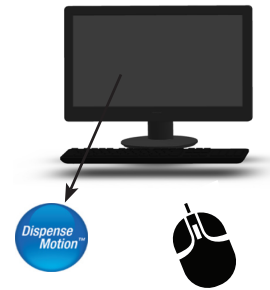

11

Click Home

- Haga Click en Inicio
- Cliquer sur Home
- Clicca Home
- Clique em Página Inicial
- Klick Home
- Klikněte Domů (Home)
- Kliknijcie Home
- Нажмите HOME (Домой)
- Klikkelj a HOME-ra
- 点击主页
- Homeをクリック
- Home 버튼 클릭

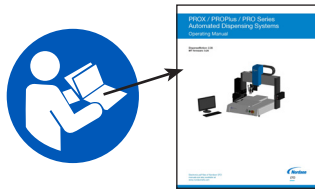
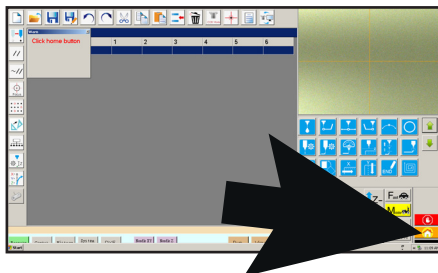

B1 Install Laser B (Option)

Instalar Láser B (Opción)
 Installer le Laser B (Option)
 Installa Laser B (Opzionale)
 Instala Laser B (Opcional)
 Laser installieren B (Optional)
 Nainstalujte Laser B (Volba)
 Zainstalować laser B (opcjonalnie)
 Установите лазер B (Опция)
 Szerelje be a lézert B (Opció)
 安装激光 B (可选)
 レーザーの取り付けB(オプション)
 레이저 설치 B (옵션항목)

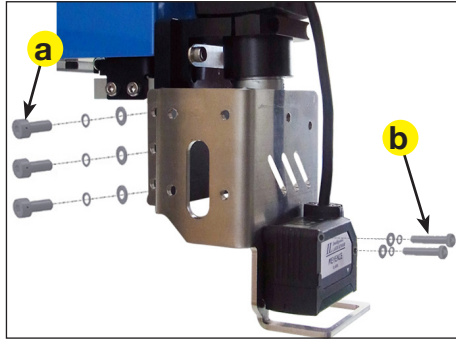

- a** M4 x 10 M4 spring washer M4 flat washer
b M3 x 30 M3 spring washer M3 flat washer

B2 Secure Wiring (Laser B)

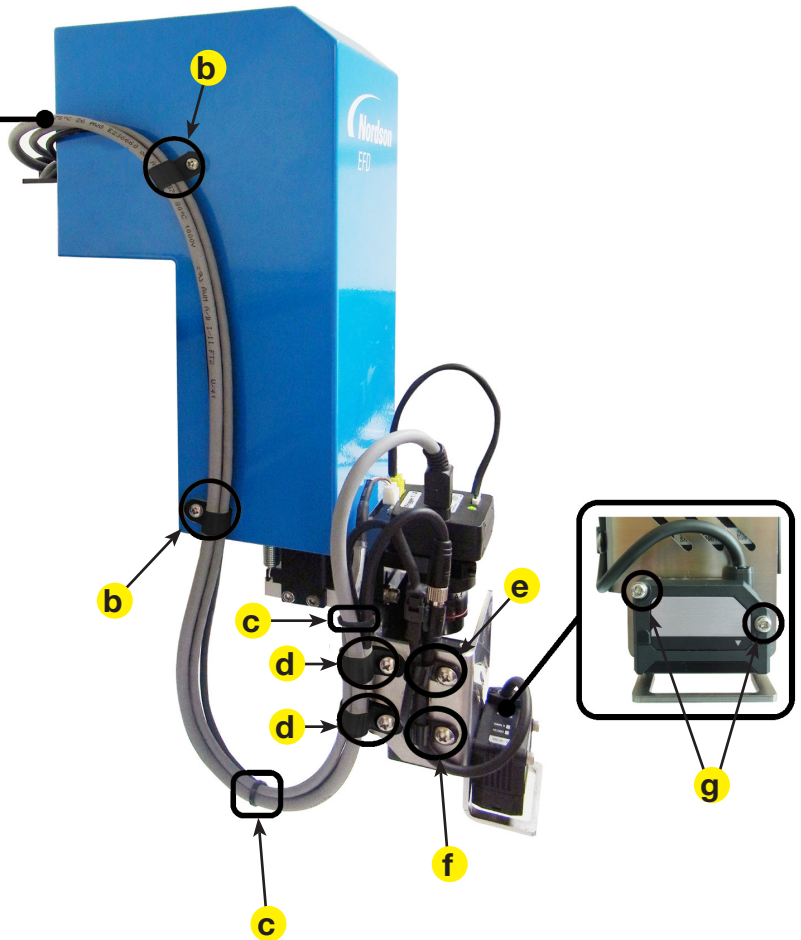
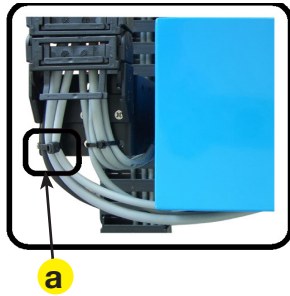

Cableado de seguridad (Láser B)
 Fixer le Câblage (Laser B)
 Fissa il cablaggio (Laser B)
 Fixação de Segurança (Laser B)
 Verdrahtung sichern (Laser B)
 Zajištění kabely (Laser B)
 Zabezpieczyć okablowanie (laser B)
 Закрепите кабели (лазер B)
 Rögzítse a kábelezést (Laser B)
 固定线缆 (激光 B)
 ケーブル類の固定(レーザーB)
 배선 정리 (레이저 B)



- a** 150 mm
b M3 x 8 3/8 (UC-3)
c 100 mm
d M4 x 6 3/8 (UC-3)
e M4 x 6 5/16 (UC-1.5)
f M4 x 6 3/16 (UC-0.5)
g M3 x 30

B3 Install Laser Controller (Laser B)

Instalar el Controlador del Láser (Láser B)
 Installer le Contrôleur du Laser (Laser B)
 Installa il controllo del laser (Laser B)
 Instala o controlo do laser (Laser B)
 Lasersteuerung installieren (Laser B)
 Naisintalujite kontrolér Laseru (Laser B)
 Zainstalować kontroler lasera (laser B)
 Установите контроллер лазера (лазер B)
 Szerelje be a lézer vezérlőjét (Laser B)
 安装激光控制器 (激光 B)
 レーザーコントローラーの取り付け (レーザーB)
 레이저 컨트롤러 설치 (레이저 B)

- a**  M4 x 12
-  M4 flat washer
-  M4 nut

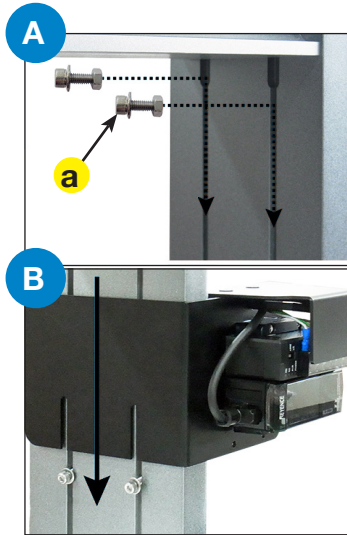

B4 Connect Cables (Laser B)

Conectar los Cables (Láser B)
 Brancher les Câbles (Laser B)
 Connetti i cavi (Laser B)
 Conecte os cabos (Laser B)
 Kabel anschließen (Laser B)
 Připojte kabel (Laser B)
 Podłączyć kabel (laser B)
 Присоедините кабели (лазер B)
 Csatlakoztassa a kábeleket (Laser B)
 连接到数据线 (激光 B)
 ケーブルの取り付け (レーザーB)
 케이블 연결 (레이저 B)

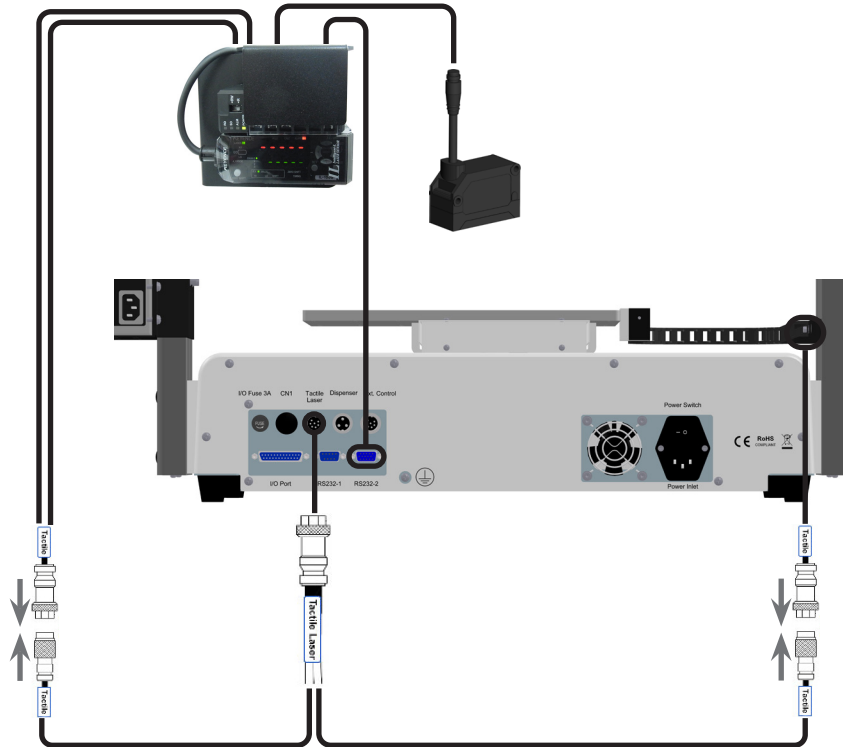

C1 Install Laser C (Option)

Instalar Láser C (Opción)
 Installer le Laser C (Option)
 Installa Laser C (Opzionale)
 Instala Laser C (Opcional)
 Laser installieren C (Optional)
 Nainstalujte Laser C (Volba)
 Zainstalować laser C (opcjonalnie)
 Установите лазер C (Опция)
 Szerelje be a lézert C (Opció)
 安装激光 C (可选)
 レーザーの取り付けC(オプション)
 레이저 설치 C (옵션항목)

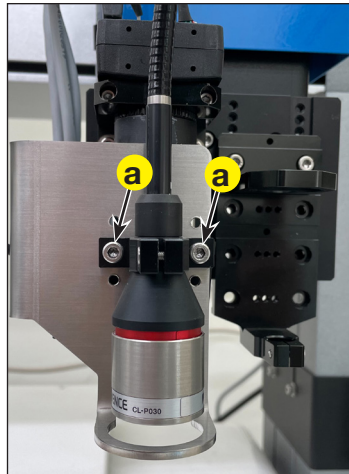







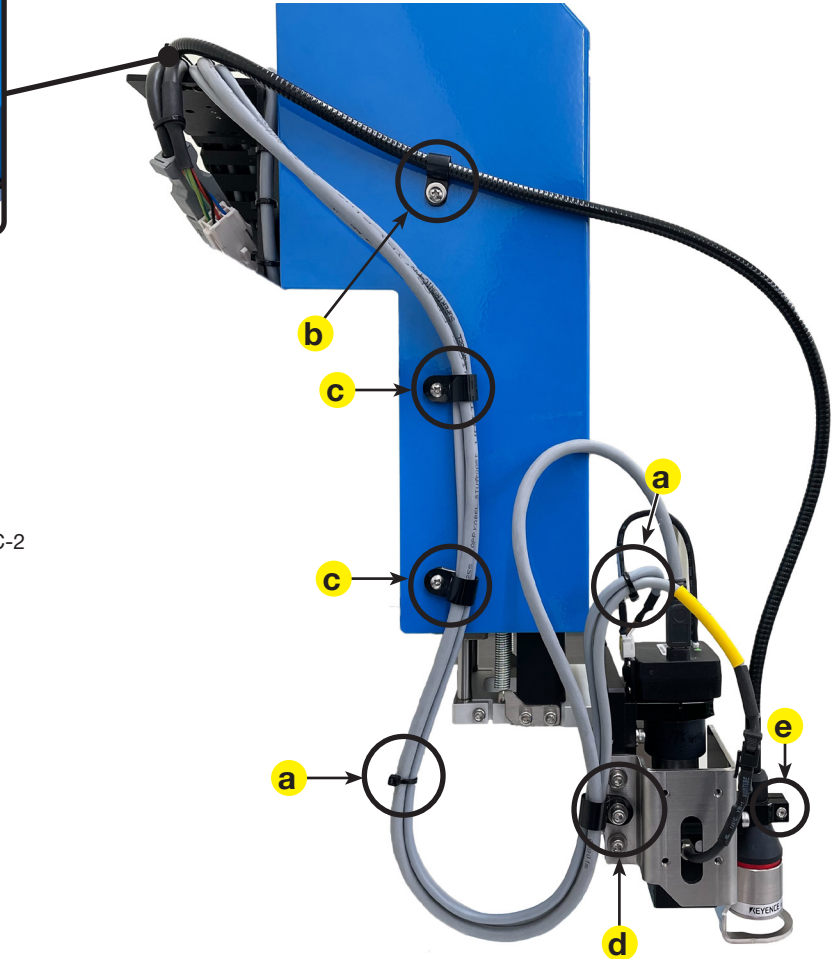
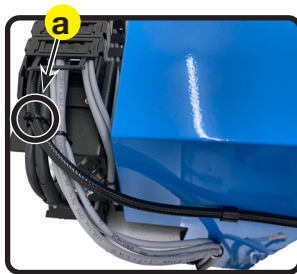

a  M4 x 10

C2 Secure Wiring (Laser C)







Cableado de seguridad (Láser C)
 Fixer le Câblage (Laser C)
 Fissa il cablaggio (Laser C)
 Fixação de Segurança (Laser C)
 Verdrahtung sichern (Laser C)
 Zajištění kabely (Laser C)
 Zabezpieczyć okablowanie (laser C)
 Закрепите кабели (лазер C)
 Rögzítse a kábelezést (Laser C)
 固定线缆 (激光 C)
 ケーブル類の固定 (レーザーC)
 배선 정리 (레이저 C)



- a**  100 mm
- b**  M3 x 8  UC-1.5
- c**  M3 x 8  UC-2
- d**  M4 x 10  M4 washer  UC-2
- e**  M3 x 10

C3 Install Laser Controller (Laser C)

Instalar el Controlador del Láser (Láser C)
 Installer le Contrôleur du Laser (Laser C)
 Installa il controllo del laser (Laser C)
 Instala o controlador do laser (Laser C)
 Lasersteuerung installieren (Laser C)
 Naisintalujite kontrolér Laseru (Laser C)
 Zainstalować kontroler lasera (laser C)
 Установите контроллер лазера (лазер C)
 Szerelje be a lézer vezérlőjét (Laser C)
 安装激光控制器 (激光 C)
 レーザーコントローラーの取り付け (レーザー-c)
 레이저 컨트롤러 설치 (레이저 C)

- a**  M4 x 5 (4)
- b**  M4 flat washer (4)
- c**  M4 nut (2)
- d**  M4 (4)
- e**  M4 (2)
- f**  M4 x 12 (2)

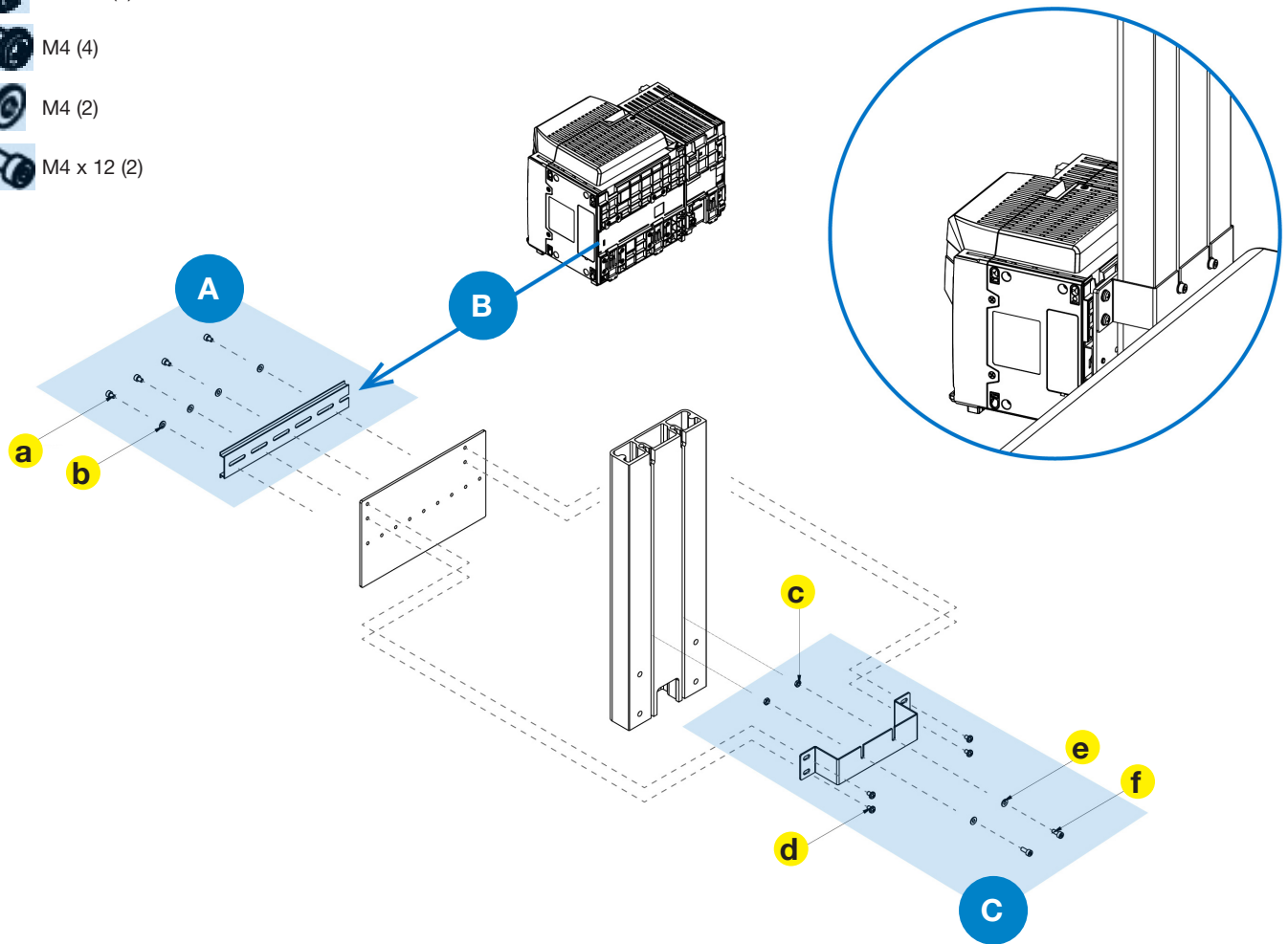

C4 Connect Cables (Laser C)

- Conectar los Cables (Láser C)
- Brancher les Câbles (Laser C)
- Connetti i cavi (Laser C)
- Conecte os cabos (Laser C)
- Kabel anschließen (Laser C)
- Připojte kabel (Laser C)
- Podłączyć kabel (laser C)
- Присоедините кабели (лазер C)
- Csatlakoztassa a kábeleket (Laser C)
- 连接到数据线 (激光 C)
- ケーブルの取り付け (レーザーC)
- 케이블 연결 (레이저 C)

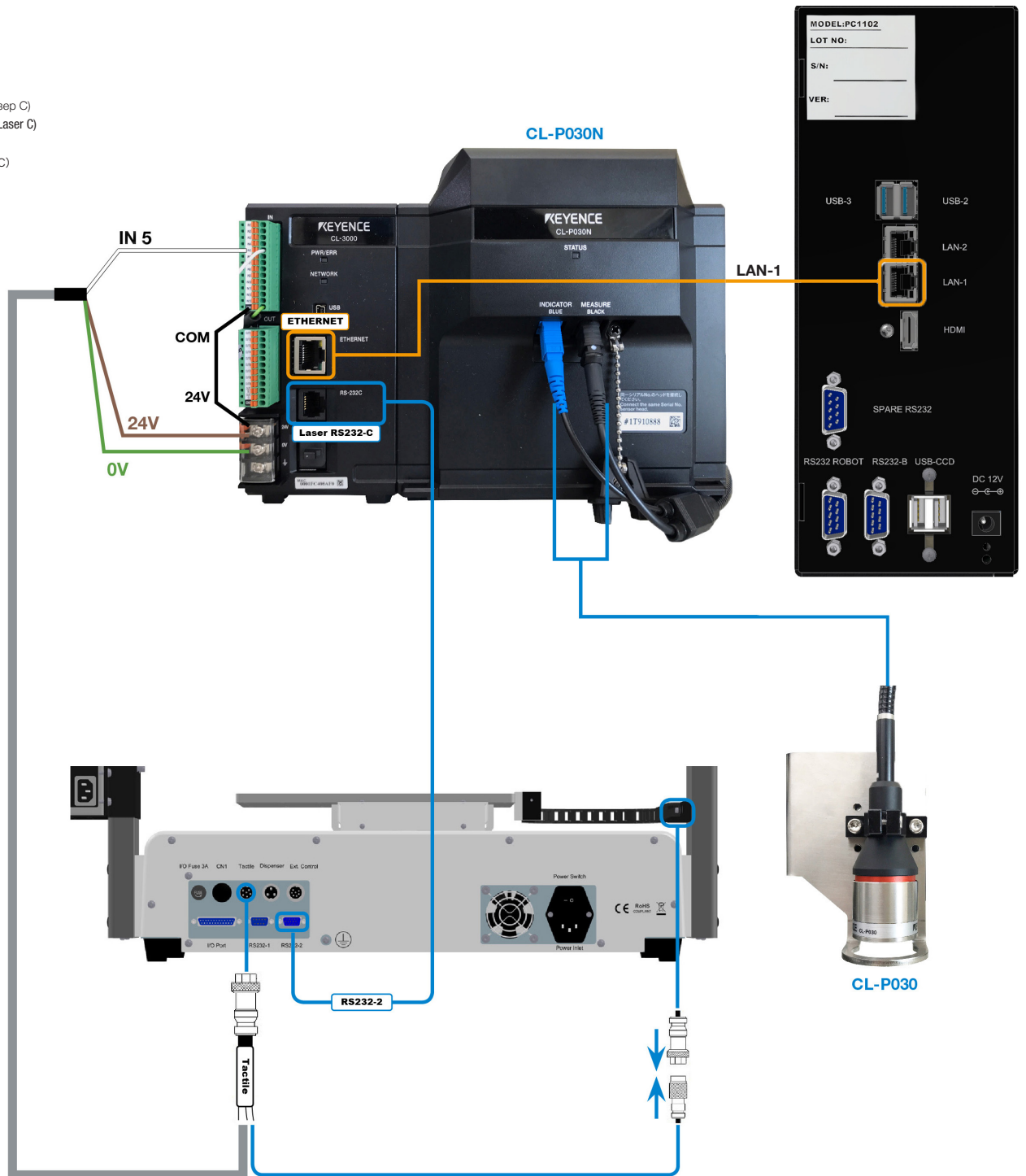



For Nordson EFD sales and service in over 40 countries, contact Nordson EFD or go to www.nordsonefd.com.

Global

800-556-3484; +1-401-431-7000
info@nordsonefd.com

Europe

00800 7001 7001
infoefd.europe@nordsonefd.com

Asia

China: +86 (21) 3866 9006; china@nordsonefd.com
India: +91 80 4021 3600; india@nordsonefd.com
Japan: +81 03 5762 2760; japan@nordsonefd.com
Korea: +82-31-736-8321; korea@nordsonefd.com
SEAsia: +65 6796 9522; sin-mal@nordsonefd.com