

Ultimus I-II High Precision Fluid Dispensers

Operating Manual



Electronic pdf files of Nordson EFD manuals are also available at www.nordsonefd.com



You have selected a reliable, high-quality dispensing system from Nordson EFD, the world leader in fluid dispensing. The Ultimus™ high precision fluid dispenser was designed specifically for industrial dispensing and will provide you with years of trouble-free, productive service.

This manual will help you maximize the usefulness of your Ultimus dispenser.

Please spend a few minutes to become familiar with the controls and features. Follow our recommended testing procedures. Review the helpful information we have included, which is based on more than 50 years of industrial dispensing experience.

Most questions you will have are answered in this manual. However, if you need assistance, please do not hesitate to contact EFD or your authorized EFD distributor. Detailed contact information is provided on the last page of this document.

The Nordson EFD Pledge

Thank You!

You have just purchased the world's finest precision dispensing equipment.

I want you to know that all of us at Nordson EFD value your business and will do everything in our power to make you a satisfied customer.

If at any time you are not fully satisfied with our equipment or the support provided by your Nordson EFD Product Application Specialist, please contact me personally at 800.556.3484 (US), 401.431.7000 (outside US), or Ferran.Ayala@nordsonefd.com.

I guarantee that we will resolve any problems to your satisfaction.

Thanks again for choosing Nordson EFD.

Ferran

Ferran Ayala, Vice President

Contents

Contents	3
Nordson EFD Product Safety Statement	4
Halogenated Hydrocarbon Solvent Hazards	5
High Pressure Fluids	5
Qualified Personnel	5
Intended Use	6
Regulations and Approvals	6
Personal Safety	6
Fire Safety	7
Preventive Maintenance	7
Important Disposable Component Safety Information	8
Action in the Event of a Malfunction	8
Disposal	8
Getting Started	9
Specifications	10
Features & Controls: Front Panel	11
Features & Controls: Back Panel	14
Initial Test Procedures	16
Setup for Testing	16
Testing in Steady Mode	16
Testing in Timed Mode	17
Testing in Teach Mode	17
Helpful Hints	18
Advanced Features (Memory)	19
To Save a Job Program	19
To Work in a Saved Job Program	19
To Edit or Clear a Saved Job	20
Menu Functions	21
Units of Pressure / Units of Vacuum	21
Language	21
Info	21
Security Code	22
Input / Output Connection	23
Voltage Initiate Circuit	23
Mechanical Contact Initiate	23
End-of-Cycle Feedback Circuit	23
Pin Function	24
Filling the Syringe Barrel	25
Filling Procedure for Pourable Low and Medium Viscosity Fluids	25
Filling Procedure for Thick Fluids	25
Filling Procedure for Watery Fluids and Vacuum Control	26
Syringe Barrel Loading Alternatives	27
Part Numbers	28
Accessories	28
Replacement Parts	28
Troubleshooting	30

Nordson EFD Product Safety Statement

WARNING

The safety message that follows has a WARNING level hazard.
Failure to comply could result in death or serious injury.



ELECTRIC SHOCK

Risk of electric shock. Disconnect power before removing covers and / or disconnect, lock out, and tag switches before servicing electrical equipment. If you receive even a slight electrical shock, shut down all equipment immediately. Do not restart the equipment until the problem has been identified and corrected.

CAUTION

The safety messages that follow have a CAUTION level hazard.
Failure to comply may result in minor or moderate injury.



READ MANUAL

Read manual for proper use of this equipment. Follow all safety instructions. Task- and equipment-specific warnings, cautions, and instructions are included in equipment documentation where appropriate. Make sure these instructions and all other equipment documents are accessible to persons operating or servicing equipment.



MAXIMUM AIR PRESSURE

Unless otherwise noted in the product manual, the maximum air input pressure is 7.0 bar (100 psi). Excessive air input pressure may damage the equipment. Air input pressure is intended to be applied through an external air pressure regulator rated for 0 to 7.0 bar (0 to 100 psi).



RELEASE PRESSURE

Release hydraulic and pneumatic pressure before opening, adjusting, or servicing pressurized systems or components.



BURNS

Hot surfaces! Avoid contact with the hot metal surfaces of heated components. If contact can not be avoided, wear heat-protective gloves and clothing when working around heated equipment. Failure to avoid contact with hot metal surfaces can result in personal injury.

Nordson EFD Product Safety Statement (continued)

Halogenated Hydrocarbon Solvent Hazards

Do not use halogenated hydrocarbon solvents in a pressurized system that contains aluminum components. Under pressure, these solvents can react with aluminum and explode, causing injury, death, or property damage. Halogenated hydrocarbon solvents contain one or more of the following elements.

Element	Symbol	Prefix
Fluorine	F	“Fluoro-”
Chlorine	Cl	“Chloro-”
Bromine	Br	“Bromo-”
Iodine	I	“Iodo-”

Check the Safety Data Sheet (SDS) or contact your material supplier for more information. If you must use halogenated hydrocarbon solvents, contact your EFD representative for compatible EFD components.

High Pressure Fluids

High pressure fluids, unless they are safely contained, are extremely hazardous. Always release fluid pressure before adjusting or servicing high pressure equipment. A jet of high pressure fluid can cut like a knife and cause serious bodily injury, amputation, or death. Fluids penetrating the skin can also cause toxic poisoning.

WARNING

Any injury caused by high pressure liquid can be serious. If you are injured or even suspect an injury:

- Go to an emergency room immediately.
- Tell the doctor that you suspect an injection injury.
- Show the doctor the following note.
- Tell the doctor what kind of material you were dispensing.

Medical Alert — Airless Spray Wounds: Note to Physician

Injection in the skin is a serious traumatic injury. It is important to treat the injury surgically as soon as possible. Do not delay treatment to research toxicity. Toxicity is a concern with some exotic coatings injected directly into the bloodstream.

Qualified Personnel

Equipment owners are responsible for making sure that EFD equipment is installed, operated, and serviced by qualified personnel. Qualified personnel are those employees or contractors who are trained to safely perform their assigned tasks. They are familiar with all relevant safety rules and regulations and are physically capable of performing their assigned tasks.

Nordson EFD Product Safety Statement (continued)

Intended Use

Use of EFD equipment in ways other than those described in the documentation supplied with the equipment may result in injury to persons or damage to property. Some examples of unintended use of equipment include:

- Using incompatible materials.
- Making unauthorized modifications.
- Removing or bypassing safety guards or interlocks.
- Using incompatible or damaged parts.
- Using unapproved auxiliary equipment.
- Operating equipment in excess of maximum ratings.
- Operating equipment in an explosive atmosphere.

Regulations and Approvals

Make sure all equipment is rated and approved for the environment in which it is used. Any approvals obtained for Nordson EFD equipment will be voided if instructions for installation, operation, and service are not followed. If the equipment is used in a manner not specified by Nordson EFD, the protection provided by the equipment may be impaired.

Personal Safety

To prevent injury, follow these instructions:

- Do not operate or service equipment unless you are qualified.
- Do not operate equipment unless safety guards, doors, and covers are intact and automatic interlocks are operating properly. Do not bypass or disarm any safety devices.
- Keep clear of moving equipment. Before adjusting or servicing moving equipment, shut off the power supply and wait until the equipment comes to a complete stop. Lock out power and secure the equipment to prevent unexpected movement.
- Make sure spray areas and other work areas are adequately ventilated.
- When using a syringe barrel, always keep the dispensing end of the tip pointing towards the work and away from the body or face. Store syringe barrels with the tip pointing down when they are not in use.
- Obtain and read the Safety Data Sheet (SDS) for all materials used. Follow the manufacturer's instructions for safe handling and use of materials and use recommended personal protection devices.
- Be aware of less-obvious dangers in the workplace that often cannot be completely eliminated, such as hot surfaces, sharp edges, energized electrical circuits, and moving parts that cannot be enclosed or otherwise guarded for practical reasons.
- Know where emergency stop buttons, shutoff valves, and fire extinguishers are located.
- Wear hearing protection to protect against hearing loss that can be caused by exposure to vacuum exhaust port noise over long periods of time.

Nordson EFD Product Safety Statement (continued)

Fire Safety

To prevent a fire or explosion, follow these instructions:

- Shut down all equipment immediately if you notice static sparking or arcing. Do not restart the equipment until the cause has been identified and corrected.
- Do not smoke, weld, grind, or use open flames where flammable materials are being used or stored.
- Do not heat materials to temperatures above those recommended by the manufacturer. Make sure heat monitoring and limiting devices are working properly.
- Provide adequate ventilation to prevent dangerous concentrations of volatile particles or vapors. Refer to local codes or the SDS for guidance.
- Do not disconnect live electrical circuits when working with flammable materials. Shut off power at a disconnect switch first to prevent sparking.
- Know where emergency stop buttons, shutoff valves, and fire extinguishers are located.

Preventive Maintenance

As part of maintaining continuous trouble-free use of this product, Nordson EFD recommends the following simple preventive maintenance checks:

- Periodically inspect tube-to-fitting connections for proper fit. Secure as necessary.
- Check tubing for cracks and contamination. Replace tubing as necessary.
- Check all wiring connections for looseness. Tighten as necessary.
- Clean: If a front panel requires cleaning, use a clean, soft, damp rag with a mild detergent cleaner. DO NOT USE strong solvents (MEK, acetone, THF, etc.) as they will damage the front panel material.
- Maintain: Use only a clean, dry air supply to the unit. The equipment does not require any other regular maintenance.
- Test: Verify the operation of features and the performance of equipment using the appropriate sections of this manual. Return faulty or defective units to Nordson EFD for replacement.
- Use only replacement parts that are designed for use with the original equipment. Contact your Nordson EFD representative for information and advice.

Nordson EFD Product Safety Statement (continued)

Important Disposable Component Safety Information

All Nordson EFD disposable components, including syringe barrels, cartridges, pistons, tip caps, end caps, and dispense tips, are precision engineered for one-time use. Attempting to clean and re-use components will compromise dispensing accuracy and may increase the risk of personal injury.

Always wear appropriate protective equipment and clothing suitable for your dispensing application and adhere to the following guidelines:

- Do not heat syringe barrels or cartridges to a temperature greater than 38° C (100° F).
- Dispose of components according to local regulations after one-time use.
- Do not clean components with strong solvents (MEK, acetone, THF, etc.).
- Clean cartridge retainer systems and barrel loaders with mild detergents only.
- To prevent fluid waste, use Nordson EFD SmoothFlow™ pistons.

Action in the Event of a Malfunction

If a system or any equipment in a system malfunctions, shut off the system immediately and perform the following steps:

1. Disconnect and lock out system electrical power. If using hydraulic and pneumatic shutoff valves, close and relieve pressure.
2. For Nordson EFD air-powered dispensers, remove the syringe barrel from the adapter assembly. For Nordson EFD electro-mechanical dispensers, slowly unscrew the barrel retainer and remove the barrel from the actuator.
3. Identify the reason for the malfunction and correct it before restarting the system.

Disposal

Dispose of equipment and materials used in operation and servicing according to local codes.

Getting Started

The Ultimus high precision fluid dispenser is designed to provide complete process control for precise, repeatable fluid dispensing.

Key features include:

- All-digital, multi-function display with simultaneous readout of air pressure, vacuum, dispense time, and deposit shot count.
- Unique air management reservoir and high-speed solenoid system for consistent, repeatable deposits.
- Time increment adjustments as small as 0.0001 seconds for precise deposit control.
- Workstation panel to hold a variety of useful accessories, such as a syringe barrel holder.

First Steps

First: Place the dispenser in your work area. The Ultimus is equipped with “stay put” rubber pads. It can be placed on the benchtop or any flat surface.

Second: Connect to power and air supplies and program the unit. For step-by-step setup instructions, see the Ultimus Quick Start Guide.

Specifications

NOTE: Specifications and technical details are subject to change without prior notification.

Item	Specification
Cabinet size	14.3W x 18.1H x 17.3D cm (5.63W x 7.12H x 6.82D")
Weight	2.3 kg (5.0 lb)
Power adapter	AC input: 100–240 VAC (+/-10%), ~50/60Hz, 0.6 Amp DC output: 24 VDC @ 1.04 Amp
End-of-cycle feedback circuits	5–24 VDC, 100 mA maximum
Cycle initiate	Foot pedal, finger switch, or 5–24 VDC signal
Cycle rate	Exceeds 600 cycles per minute
Time	Range: 0.0001–999.9999 s Accuracy: Within ±0.05% of the selected time setting Repeatability: Less than 16 µsec at any time setting
Input air pressure	5.5–7.0 bar (80–100 psi)
Air output	Ultimus I: 0–7.0 bar (0–100 psi) Ultimus II: 0–1.0 bar (0–15 psi)
Pressure readout accuracy	Ultimus I: ±0.1 bar (±2.0 psi) Ultimus II: ±0.2 bar (±0.3 psi)
Vacuum	0–1.3 inHG (0–18 inH ₂ O)
Vacuum readout accuracy	±0.15 inHG (±2.0 inH ₂ O) NOTE: Vacuum readout accuracy is calibrated from 0–0.44 inHG (0–6 inH ₂ O).
Ambient operating conditions	Temperature: 5–45° C (41–113° F) Humidity: 85% RH at 30° C non-condensing Height above sea level: 2000 m maximum (6,562 ft)
Approvals	CE, UKCA, TUV, RoHS, WEEE, China RoHS

RoHS标准相关声明 (China RoHS Hazardous Material Declaration)

产品名称 Part Name	有害物质及元素 Toxic or Hazardous Substances and Elements					
	铅 Lead (Pb)	汞 Mercury (Hg)	镉 Cadmium (Cd)	六价铬 Hexavalent Chromium (Cr6)	多溴联苯 Polybrominated Biphenyls (PBB)	多溴联苯醚 Polybrominated Diphenyl Ethers (PBDE)
外部接口 External Electrical Connectors	X	0	0	0	0	0
<p>0: 表示该产品所含有的危险成分或有害物质含量依照EIP-A, EIP-B, EIP-C的标准低于SJ/T11363-2006 限定要求。 Indicates that this toxic or hazardous substance contained in all the homogeneous materials for this part, according to EIP-A, EIP-B, EIP-C is below the limit requirement in SJ/T11363-2006.</p> <p>X: 表示该产品所含有的危险成分或有害物质含量依照EIP-A, EIP-B, EIP-C的标准高于SJ/T11363-2006 限定要求。 Indicates that this toxic or hazardous substance contained in all the homogeneous materials for this part, according to EIP-A, EIP-B, EIP-C is above the limit requirement in SJ/T11363-2006.</p>						

WEEE Directive



This equipment is regulated by the European Union under WEEE Directive (2012/19/EU). Refer to www.nordsonefd.com/WEEE for information about how to properly dispose of this equipment.

Features & Controls: Front Panel

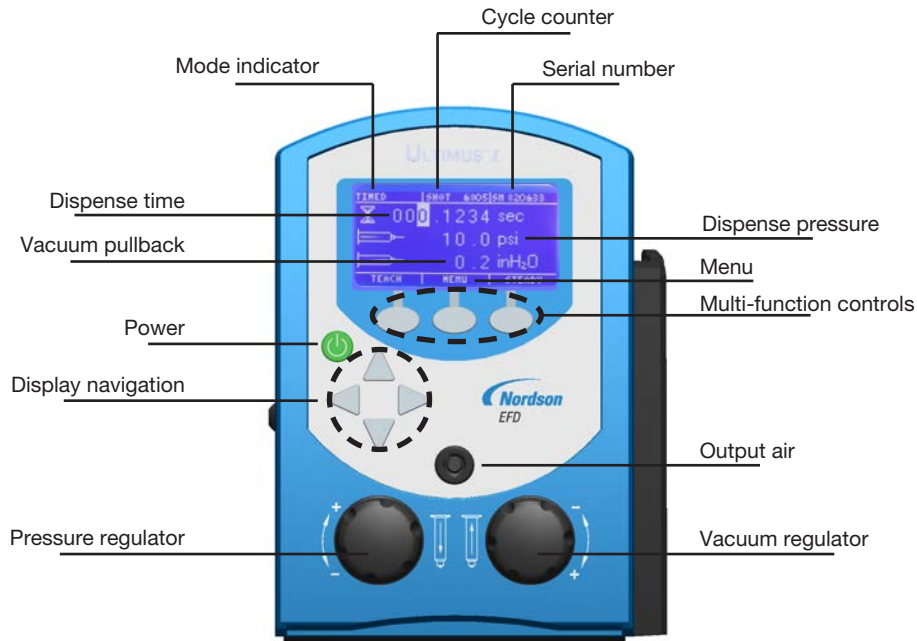

Dispense Mode

When powered on for the first time, the Ultimus Home screen displays in TIMED mode. Otherwise, it displays in the mode last used.

You can verify the mode by checking the top left corner of the display screen. It will be TIMED, TEACH, STEADY, or MEMORY.

- You can return to TIMED mode from TEACH or STEADY by pressing TIMED in the bottom right corner of the display.
- You can return to TIMED mode from MEMORY by pressing MENU, then selecting TIMED.

See the appropriate section below for details on each dispense mode.

Timed Mode









Dispense Time

Dispense time, shown with an hourglass icon, displays from 000.0001 to 999.9999 seconds. Follow these steps to set the dispense time.

1. Begin in TIMED mode.
2. Press the left / right arrows to highlight the first number you want to change.
3. Press the up / down arrows to set the dispense time.
4. Repeat as needed to adjust the other numbers in the dispense time row.



See the Ultimus Icon Guide, included with your dispensing system, if you are working in Chinese, Japanese, or Korean. Sample icons:

 (Timed)
  (Steady)
  (Teach)
  (Menu)
  (Select)
  (Home)

Features & Controls: Front Panel (continued)

Air Pressure

Air pressure is displayed in psi. See page 21 to change the display of pressure from psi to bar or kPa. It is shown with the icon of an arrow pushing into a syringe barrel. Follow these steps to set air pressure.

1. Pull the air pressure regulator knob out to unlock it (bottom left knob).
2. Turn the knob clockwise to increase the pressure or counterclockwise to decrease the pressure.
3. Push the knob in to lock the pressure setting.



CAUTION

A pressure regulator of 0–7.0 bar (0–100 psi) is intended to be provided before connecting the unit to the air supply.

4. Set the plant air supply to within 5.5–7.0 bar (80–100 psi).

Vacuum

Vacuum is displayed in inH₂O (inches of water). See page 21 to change the display of vacuum from inH₂O to inHg, kPa, mmHg, or Torr. It is shown with the icon of an arrow pulling out of a syringe barrel. Follow these steps to set vacuum pressure.

1. Pull the vacuum regulator knob out to unlock it (bottom right knob).
2. Turn the knob clockwise to the desired setting. You can adjust the vacuum in increments of 0.1 inH₂O.
3. Push the knob in to lock the vacuum setting.



CAUTION

Use EFD filter / muffler P/N 7017049 or wear adequate ear protection when operating the vacuum in close proximity for a prolonged period of time.

Power

Press the power button to turn the unit on. A Nordson EFD logo will briefly appear before the Home screen displays. The Ultimus will go into sleep mode when it is inactive for more than 90 minutes. Simply press any button or the foot pedal to reactivate the screen.

Features & Controls: Front Panel (continued)

Menu

You can access the menu screen by pressing MENU. From here press the up / down and left / right arrows to select from a variety of screens, including:

TIMED	TEACH	MEMORY
CLEAR COUNT	UNITS OF PRESSURE	UNITS OF VACUUM
SECURITY	LANGUAGE	SAVE JOB
INFO		



Refer to “Menu Functions” on page 21 for more information on Menu functions.

Shot Count

The shot count is displayed in the top center section of the display screen. It displays the number of deposits that have been dispensed. Follow these steps to reset the shot count.

1. Press MENU.
2. Press the down arrows to scroll to CLEAR COUNT.
3. Press SELECT. This resets the shot count to 0 and automatically returns you to the Home screen.

Timed Mode

In TIMED mode, the Ultimus will dispense a single deposit each time you press the foot pedal or finger switch. Deposit size is based on dispense time and pressure settings shown on the display.

Steady Mode

In STEADY mode you can dispense for as long as you press the foot pedal or finger switch. From TIMED mode, press STEADY. This toggles the display so that the top left corner is now shows the STEADY mode. Refer to “Initial Test Procedures” on page 16 for more details on STEADY mode.

Teach Mode

In TEACH mode you can “teach” the deposit based on physical size. Begin at the Home screen for TIMED mode. Press TEACH. This toggles the display so that the top left corner is now shows the TEACH mode. Refer to “Initial Test Procedures” on page 16 for more details on TEACH mode.

Output Air Port

The Ultimus features one air port on front panel to provide regulated air pressure to the syringe barrel. You can connect the Optimum™ adapter assembly to the port on the front panel.

- Push the black quick-connect from the EFD adapter assembly into the air output port and twist to lock.

NOTE: Air does not flow through the port until a quick-connect is installed.

Features & Controls: Back Panel

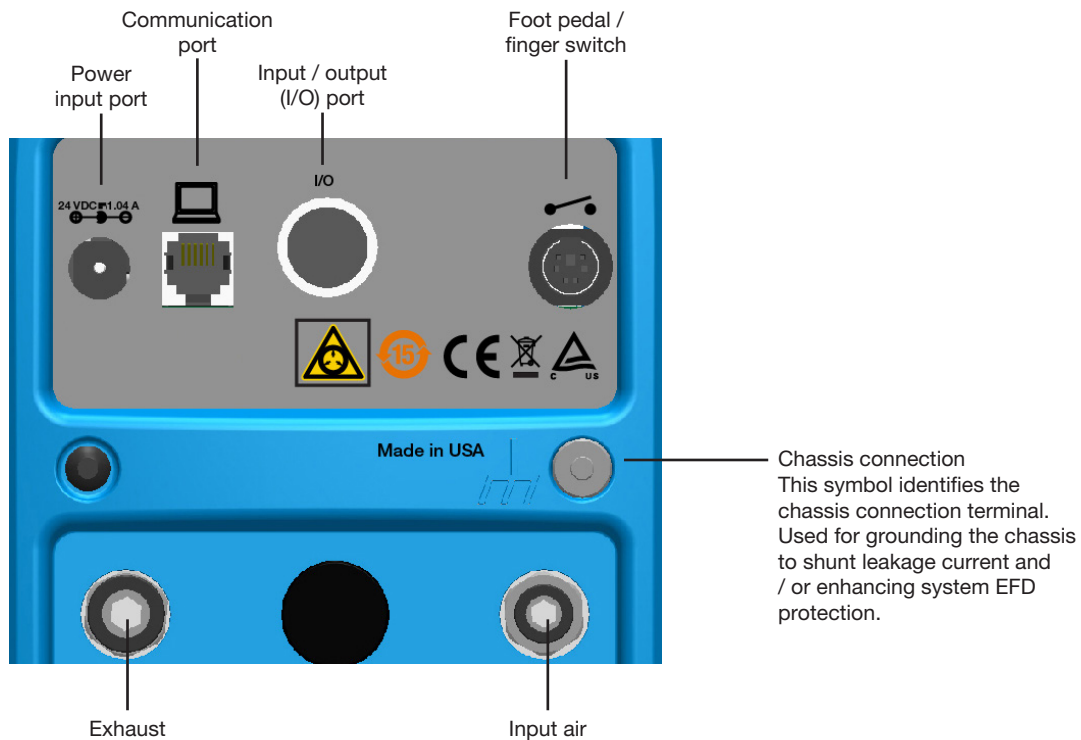

Power Input Port

The power input port is located at the top left corner of the Ultimus. The Ultimus power pack automatically adjusts for 100 to 240 VAC.

Use only the universal power pack provided with the Ultimus workstation. The unit is shipped with four power plugs (one USA and three international plugs) and an 1800 mm (5.9 ft) length power cord.

- Connect the DC plug from the cord to the Ultimus power input port.
- Connect the power cord to your local power source.

Communication Port

The Ultimus communication port, located on the top row of ports, is for EFD use only.

Input / Output 8-Pin Interface Connector

Input / output features are used when the Ultimus is interfaced with external control circuits. The 8-pin connector is located on the top row of ports. Refer to “Input / Output Connection” on page 23 for details.

- An End-of-Cycle signal, in the form of an electronic switch, closes upon completion of the dispense cycle.

Features & Controls: Back Panel (continued)

Foot Pedal / Finger Switch Port

The switch port, a 6-pin mini DIN connection, is located on the top right corner of the Ultimus. It is used to connect the foot pedal or finger switch that activates the dispense cycle. Be sure to align the foot pedal or finger switch cord connector so that arrow on the connector is on top.

Exhaust Port

The exhaust port is the larger 8 mm pneumatic fitting located at the bottom left corner of the Ultimus workstation.

- If needed, you can connect a cleanroom filter muffler to filter output air to meet Fed 209-B (0.5 micron particulates). For dispenser accessories, refer to “Accessories” on page 28.

CAUTION

Use EFD filter / muffler P/N 7017049 or wear adequate ear protection when operating the vacuum in close proximity for a prolonged period of time.

Air Input Port

The air input port is the smaller pneumatic fitting (6 mm) located at the bottom right corner of the Ultimus workstation.

1. Push one end of the 6 mm air input tubing into the air input fitting on the back of the Ultimus. A 2.4 mm (8 ft) length of air tubing is provided.
2. Connect the other end of the air input tubing to your plant air supply. A standard 1/4 NPT fitting is included with your unit.

NOTE: Clean, dry filtered factory air is required to meet warranty. If your air supply is not filtered, order the 5-micron filter regulator. For dispenser accessories, refer to “Accessories” on page 28.

WARNING

Bottled nitrogen can be used. If high pressure bottled air or nitrogen is used, a high pressure regulator must be installed on the bottle and set at 7.0 bar (100 psi) maximum. In this instance, the 5-micron filter regulator is not required.

CAUTION

A pressure regulator of 0–7.0 bar (0–100 psi) is intended to be provided before connecting the unit to the air supply.

Initial Test Procedures

Deposit size is controlled by dispense time, pressure, and tip size.

Follow these instructions to test each function. Use the convenient Dot Standards sheet included in your dispensing system kit.

NOTE: Tips and helpful suggestions for setup are provided under “Helpful Hints” on page 18. Refer to this information as needed during initial setup and testing.

Setup for Testing

1. Attach an EFD syringe barrel filled with your assembly fluid to the adapter assembly as shown.
2. Keep the vacuum set at 0.0 during initial testing. (If you are dispensing a watery fluid, refer to “Filling Procedure for Watery Fluids and Vacuum Control” on page 26.)
3. Replace the blue tip cap with an EFD precision dispense tip.
4. Slide the syringe barrel into the hand grip. Snap in place.
5. Run through the following tests to demonstrate the ease at which deposit sizes can be established using the various dispense modes.

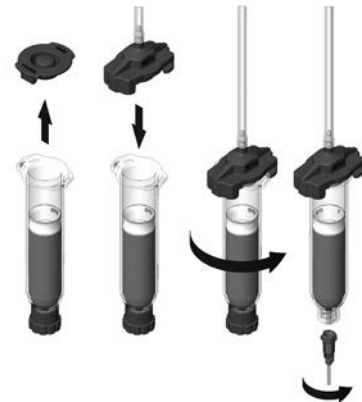

Testing in Steady Mode

1. Select STEADY mode.
2. Pull the air pressure regulator knob out until it clicks into the unlocked position. Start with pressure set to 0.0 bar (0 psi).
3. Press and hold the foot pedal or finger switch.
4. Slowly, turn the pressure knob clockwise until your fluid begins to dispense out of the tip in a controlled flow (not too fast, not too slow).
5. Push the air pressure knob in to lock the setting.



Remember - always bring the tip in contact with the work surface at the illustrated angle. After the tip is in position, press the foot pedal. Release the pedal and remove the tip by lifting straight up.

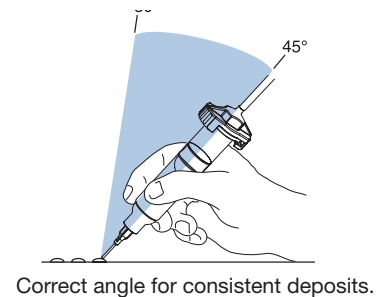

Initial Test Procedures (continued)

Testing in Timed Mode

1. Refer to “Testing in Steady Mode” on page 16 to purge your dispensing tip with fluid.
2. Change to TIMED mode.
3. Set the time to 000.0250 seconds.
4. Rest the dispense tip on the Dot Standards sheet.
5. Press the foot pedal (or finger switch) to activate the dispense cycle.
NOTE: The pedal only needs to be pressed for a moment. The complete time will run once you activate the dispense cycle.
6. **Changing the time changes the deposit size.** If your dot is too small, increase the dispense time to increase the deposit size. If your dot is too large, decrease the dispense time to decrease the deposit size.

Testing in Teach Mode

1. Refer to “Testing in Steady Mode” on page 16 to purge the dispensing tip with fluid.
2. Change to TEACH mode by going to the menu and scrolling to TEACH.
3. Rest the dispense tip on the Dot Standards sheet.
4. Press the foot pedal to establish your dot size. Depressing the foot pedal repeatedly will have a cumulative effect on the dot size and dispense time.
5. Continue to press the foot pedal until you achieve the correct deposit size.
6. If needed, press CLEAR to start over.
7. Save the dispense time setting you just created by pressing SAVE. This automatically exits TEACH mode and returns you to TIMED mode.

Initial Test Procedures (continued)

Helpful Hints

- There are three core variables for setting up the Ultimus high precision fluid dispenser: dispense time, pressure, and vacuum. Adjust just one of these at a time, in small increments, to achieve the correct deposit.
- Another important variable is tip size. Choose the right tip for the deposit type. Remember, smaller tips require more pressure and more time. Try different tips without changing the time or pressure settings and observe the results.
- Tapered tips reduce the amount of air pressure needed to dispense thick materials. They also help prevent drooling at the end of a dispense cycle.
- To ensure smooth fluid flow and to make consistent deposits, keep the dispense tip at a 45° angle to the work surface.
- Use EFD SmoothFlow pistons to make barrel loading, dispensing, and fluid handling cleaner, safer, and more accurate.

CAUTION

If you dispense watery fluids and choose not to use EFD pistons, do not increase vacuum pressure rapidly and do not tip the barrel. Vacuum may pull fluid into the adapter hose, or, if the syringe barrel is tipped, fluid may flow back into the dispenser.

- Always use new EFD syringe barrels and tips. Carefully dispose of after use. This procedure ensures maximum cleanliness, prevents contamination, and provides proper safety.
- Do not completely fill the syringe barrel. For most fluids, optimum fill is a maximum 2/3 of the barrel capacity. For cyanoacrylates or watery fluids, optimum fill is 1/2 of the barrel capacity.

Suggestions on Settings

- Avoid high pressure settings with very short time settings (example: 5.5 bar / 80 psi at less than 000.0100 seconds). The ideal setup matches air pressure and tip size to produce a “workable” flow rate – no splashing, but not too slow either – with a time setting that is not extremely low.
- With any fluid, always give the air pressure time to do its job. Moderate time and pressure provides the best results since dispensing pressure remains at its peak for a longer period of time.
- Longer dispense time settings generally provide the highest accuracy. However, in the interest of cost-effective production, do not use excessively long dispense time settings. Experiment to find what works best for your application.

Advanced Features (Memory)

The Ultimus high precision dispenser allows you to store the dispense time, pressure, and vacuum settings for up to 16 different job programs. Programs are saved even with power removed and will remain in storage unless changed or erased intentionally.

Job programs are identified as Memory 1 through Memory 16.

NOTE: Dispense time is automatically adjusted when you select an individual job program. Settings for pressure and vacuum are stored and can be displayed but you need to manually adjust the pressure and vacuum regulator knobs to match the stored settings for these values.

To Save a Job Program

1. From TIMED or TEACH mode, set the dispense time, air pressure, and vacuum settings to create a correct deposit size. When you are in TEACH mode, press SAVE after you create your settings, then return to TIMED mode.
2. Press MENU. Use the up / down arrows to scroll to SAVE JOB. Press SELECT.
3. Use the up / down arrows to select the correct job program in which to save these settings (example, Memory 1 or Memory 2).
Remember: To prevent accidental data loss, review the contents of each job program before selecting and storing a new job into memory.
4. Press SAVE. This automatically saves the settings in the job program.

To Work in a Saved Job Program

1. Press MENU. Use the up / down arrows to highlight MEMORY. Press SELECT.
2. Use the up / down arrows to scroll through the individual jobs until you reach the correct Memory number.
3. Press and hold SETTINGS to see the stored pressure and vacuum settings for the job.
Remember: Dispense time automatically adjusts when you select a job program. Releasing the SETTINGS button displays the current values for pressure and vacuum, not the stored values. To retrieve the stored values, manually adjust air pressure and vacuum based on the pressure and vacuum shown when you press Settings.
4. Press the foot pedal or finger switch to activate the dispense cycle. The Ultimus will automatically make the deposit based on the settings in the selected job program.
5. To escape from Memory, press MENU. Then press TIMED to return to the Home screen. At this point, you are still in the current memory setting for the previous job program, but you are free to change time, pressure, and vacuum without impacting the stored settings in memory.

Advanced Features (Memory) (continued)

To Edit or Clear a Saved Job

Follow these steps to make changes to an existing job.

1. Press MENU. Use the up / down arrows to highlight MEMORY. Press SELECT.
2. Use the up / down arrows to select the correct job program to edit (Memory 1, Memory 2, etc.).
3. If you need to review the stored values for pressure and vacuum, press and hold SETTINGS. You can adjust the pressure and vacuum from this screen, or you can make adjustments from TIMED mode. However, you can only adjust the dispense time setting from the TIMED mode screen.
4. Press MENU again.
5. Press TIMED to return to TIMED mode in the selected program.
6. Adjust the settings for dispense time, air pressure, and vacuum as needed to achieve the correct deposit size.
7. Press MENU.
8. Use the up / down arrows to highlight SAVE JOB. Press SELECT.
9. Use the up / down arrows to again select the correct job program.
10. Press SAVE. This automatically saves the changed settings and returns you to the Home screen.

NOTE: To clear all settings in a specific job program, simply set the time, pressure, and vacuum to 0 (step 6) and follow the other steps as noted.

Menu Functions

You can access the menu screen by pressing MENU. From here press the up / down and left / right arrows to select from a variety of screens.

Units of Pressure / Units of Vacuum

You can change the screen display of air pressure units from psi to bar or kPa, or for vacuum units from inH₂O to inHg, kPa, mmHg, or Torr. Follow these steps:

1. Press MENU.
2. Press the up / down arrows to highlight UNITS OF PRESSURE or UNITS OF VACUUM, then press SELECT.
3. Press the up / down arrows to highlight the appropriate pressure or vacuum display option.
4. Press SELECT again to make the change. This automatically returns you to the Home screen.



Language

You can change the screen display from English to another language. Follow these steps.

1. Press MENU.
2. Press the up / down arrows to highlight LANGUAGE, then press SELECT.
3. Press the up / down arrows to highlight the appropriate option.
4. Press SELECT again to make the change. This automatically returns you to the Home screen.

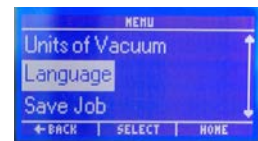

Info

The Info screen displays the Ultimus workstation's model number, part number, version, serial number, contact website, and telephone number for customer service. To view INFO, press MENU, use the up / down arrows to highlight INFO, then press SELECT.

An LCD contrast adjustment utility is available on the INFO screen by pressing the center button LCD. A graphic setpoint indicator appears when selected. Press the left / right arrows to optimize visibility for an individual viewing angle. Press LCD to retain changes; press BACK or HOME to discard changes.

Menu Functions (continued)

Security Code

You can set a 4-digit password to prevent job changes by unauthorized users. This password locks out the ability to change dispense time, clear the shot count, or modify settings in Memory. The password is required to access the Security screen. Unauthorized users get a Password Error message if an invalid password is used.

To select the functions to password protect

1. Press MENU.
2. Press the up / down arrows to highlight SECURITY, then press SELECT.
3. For first time use, enter 0000 as the password and press ENTER (0000 is the default setting) or enter the current password.
4. Press the up / down arrows to highlight the functions to protect (Memory, Shot Count, and Time).
5. Press SELECT to toggle between adding or deleting a check mark next to each function. To protect the function from unauthorized changes, add the check mark. Delete the check mark to allow or change settings.
6. Press HOME to return to the Home screen.

To change the password

1. Press MENU.
2. Press the up / down arrows to highlight SECURITY, then press SELECT.
3. For first time use, enter 0000 as the password and press ENTER (0000 is the default setting) or enter the current password.
4. Press PASSWORD.
5. Press the left / right arrows to highlight the first number.
6. Press the up / down arrows to set the number.
7. Repeat to adjust the other numbers in the 4-digit code.
8. Press ENTER. This puts you in the Security screen and automatically stores the new password.
9. Press HOME to return to the Home screen.

Input / Output Connection

Voltage Initiate Circuit

The Ultimus workstation may be initiated with a 5 to 24 VDC signal across pins 1 and 2. The signal can be momentary (no less than 0.01 seconds) or maintained. A new cycle will begin after the signal is removed and then applied again.

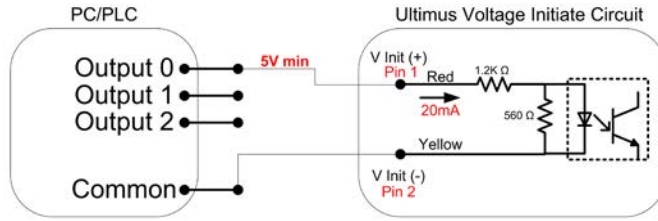

Dispense control with voltage initiate

Mechanical Contact Initiate

The Ultimus can be initiated via the closure of mechanical contacts such as a relay or switch using pins 7 and 8. Closure of the contacts can be momentary (no less than 0.01 seconds) or maintained. A new cycle will begin once the contacts are opened and then closed again.

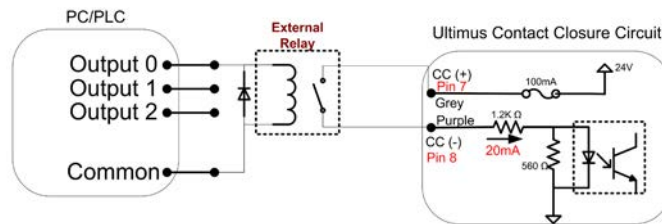

PC/PLC contact closure interface

End-of-Cycle Feedback Circuit

A normally closed electronic switch opens at the start of the dispense cycle and closes at the conclusion of the dispense cycle. The End-of-Cycle feedback on pins 3 and 4 can acknowledge an active dispense cycle to external equipment.

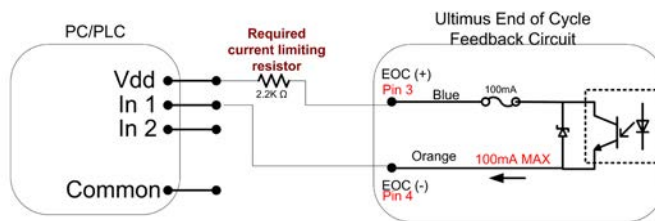

End of Cycle feedback to PC/PLC

Input / Output Connection (continued)

Pin Function

An 8-pin DIN cable assembly is available. For dispenser accessories, refer to “Accessories” on page 28.

Cable Wire Color	Pin #	Function
Red	1	Voltage initiate +, 5–24 VDC (19 mA maximum)
Yellow	2	Voltage initiate -
Blue	3	End-of-cycle feedback output +, 5–24 VDC (100 mA maximum)
Orange	4	End-of-cycle feedback output -
Green	5	24 VDC supply + (100 mA maximum)
Brown	6	24 VDC supply -
Grey	7	Contact closure +, 24 VDC @ 19 mA
Purple	8	Contact closure -

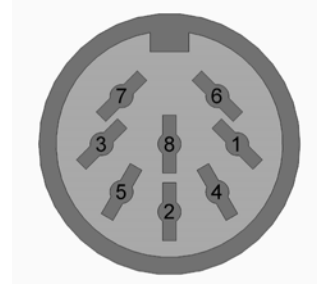

Back panel I/O pin diagram

Filling the Syringe Barrel

⚠ CAUTION

Do not completely fill syringe barrels. The optimum fill is a maximum 2/3 of the barrel capacity and 1/2 of the barrel capacity when using the EFD blue LV Barrier™ piston.

For best results, we strongly recommend that you use a piston as part of your dispensing system. The white EFD SmoothFlow piston is appropriate for most fluids and has several advantages:

- First, vacuum adjustment is less sensitive.
- Second, the piston prevents fumes from the fluid being exhausted into the work environment.
- Third, the piston prevents fluid backflow into the dispenser if the syringe barrel is inadvertently turned upside down.
- Fourth, the piston makes it easy and safe to change tips without dripping.

For watery solvents and cyanoacrylates, request the blue EFD LV Barrier piston, available in 3cc, 10cc, and 30cc sizes. If you are dispensing an RTV silicone and find that the piston bounces and causes stringing, request the EFD Clear Flex piston.

Remember

For best results, EFD strongly recommends the use of a piston as part of your dispensing system.



SmoothFlow piston prevents fluid backflow.

If you choose to not use a piston when dispensing thin fluids, remember these important points.

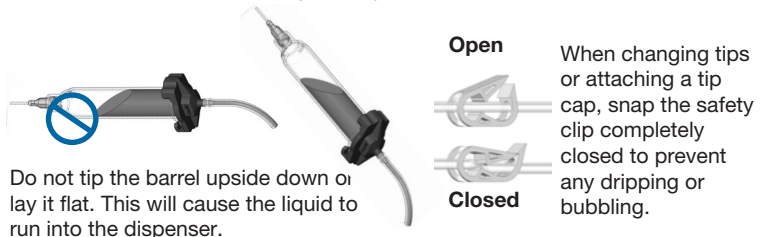

Filling Procedure for Pourable Low and Medium Viscosity Fluids

If the fluid you are dispensing is pourable, take the syringe barrel, twist on a blue tip cap, and pour your fluid in. Insert a white SmoothFlow piston and carefully press down until it contacts the fluid. The syringe barrel is now ready for use.

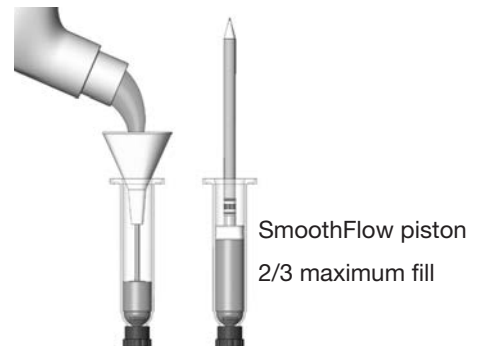

Filling Procedure for Thick Fluids

If your fluid is thick or non-leveling, you can spoon it into the syringe barrel with a spatula. Or, if the fluid comes packed in a 300 ml (1/10 gallon) cartridge, try loading the barrel with a caulking gun. Then, press the SmoothFlow piston to move the fluid to the bottom of the syringe barrel and remove trapped air.

Trapped air in thick fluids can lead to drooling and oozing. Also, repetitive air cycles can bore tunnels through non-leveling fluids, causing spitting and inconsistent deposits. The SmoothFlow piston eliminates these problems. It prevents tunneling by providing a barrier to the pulsed-air cycles. And it prevents oozing by responding to the pressure of trapped air with a slight suck-back movement after the dispense cycle.



Filling the Syringe Barrel (continued)

Filling Procedure for Watery Fluids and Vacuum Control

The Ultimus vacuum regulator allows low viscosity fluids, even water, to be consistently dispensed without dripping between cycles. A vacuum is exerted above the fluid in the barrel to prevent dripping. For medium to high viscosity fluids, the recommended vacuum setting is 0.0.

If you are dispensing watery solvents, cyanoacrylates, or anaerobics, request the blue LV Barrier piston and follow these steps to fill the syringe barrel and set the vacuum control.

1. Twist a blue tip cap onto an empty syringe barrel and pour your fluid in. Insert the blue LV Barrier piston. Allow an air gap between piston and fluid as shown. (If you are using the SmoothFlow piston, push the white piston down until it comes in contact with the fluid.)
2. Attach the syringe to the EFD adapter assembly.
3. Snap the safety clip tightly closed to prevent any dripping.
4. Remove the tip cap and attach a precision dispense tip.
5. Set air pressure at 0.1 bar (2 psi).
6. From TIMED mode, press STEADY.
7. With the syringe barrel pointing down over a container, unsnap the safety clip. Press and hold the foot pedal or finger switch to fill the tip.
8. As a drop begins to form at the end of the tip, slowly turn the vacuum regulator knob clockwise to stop the drip. Wipe the tip and adjust the vacuum as necessary.
9. Return to TIMED mode.
10. Rest the tip on the Dot Standards sheet. Press the foot pedal and release. Check the dot size. Increase or decrease by adjusting pressure or time as needed.

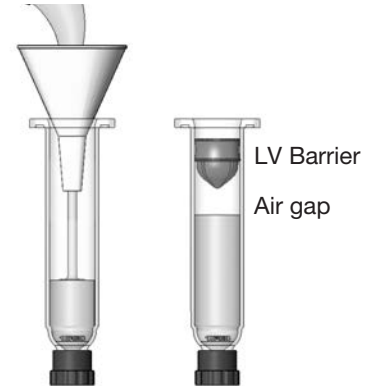

CAUTION

Use EFD filter / muffler P/N 7017049 or wear adequate ear protection when operating the vacuum in close proximity for a prolonged period of time.

NOTE: For best results when dispensing watery-thin fluids, Nordson EFD recommends the use of the vacuum suck-back filter trap. This is guaranteed to prevent fluid from being sucked back into the dispenser. For dispenser accessories, refer to “Accessories” on page 28.

Syringe Barrel Loading Alternatives

Nordson EFD offers productive alternatives to traditional syringe barrel loading methods. Here are a few suggestions that can help keep your work area clean, save time, and reduce the chance of entrapped air in the fluid.

- Use the Atlas™ Filling System, P/N 7022445 (12 fl oz). Pack the fluid into a 2.5 fl oz, 6 fl oz, 12 fl oz, 20 fl oz, or 32 fl oz cartridge as shown. Then place the pre-filled cartridge into the barrel loader. Using air pressure, the barrel loader fills the syringe barrel (with a piston installed) from the bottom up.

If the fluid comes packed in a 300 ml (1/10 gallon) caulking type cartridge, use the EFD P/N 7022452 filling system.

- If you receive frozen epoxies or other fluids in medical type syringes with a manual plunger, request the EFD luer-to-luer fitting to transfer the material.

Contact an EFD fluid application specialist for additional assistance.

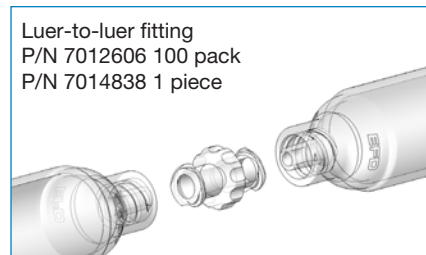
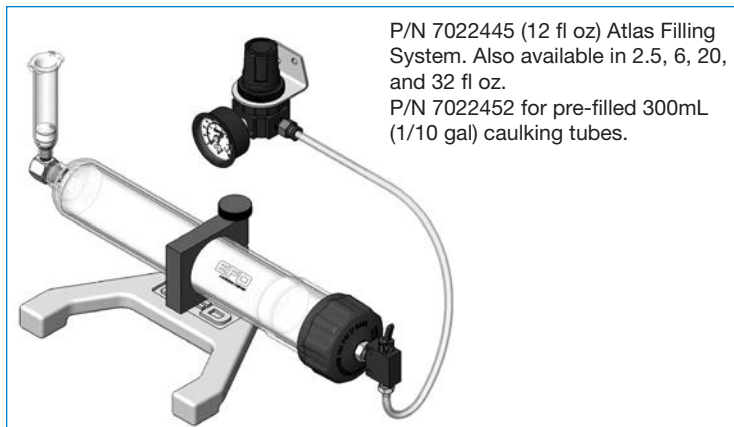

Part Numbers



Part #	Description
7017041	Ultimus I dispenser, 0–7 bar (0–100 psi)
7012584	Ultimus I dispenser, 0–7 bar (0–100 psi) calibrated to EFD specifications based on NIST standards
7002003	Ultimus II dispenser, 0–1 bar (0–15 psi)
7012586	Ultimus II dispenser, 0–1 bar (0–15 psi) calibrated to EFD specifications based on NIST standards

Accessories

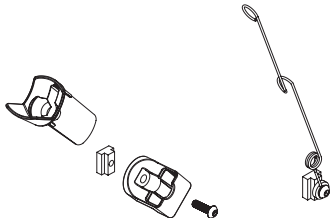

See the Dispenser Accessories data sheet for a complete list of optional accessories that will maximize the performance of your dispenser. Visit www.nordsonefd.com/DispenserAccessories for details.

Replacement Parts

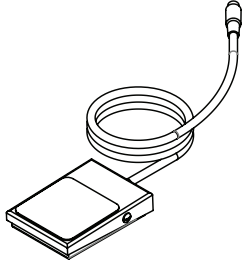
NOTE: Refer to the Nordson EFD catalog for Optimum components, including syringe barrels, adapter assemblies, pistons, dispensing tips, and tip caps.

Item	Part #	Description
	7364472	Barrel accessories
	7017133	Barrel hand grip
	7363157	Foot pedal assembly
<i>Continued on next page</i>		

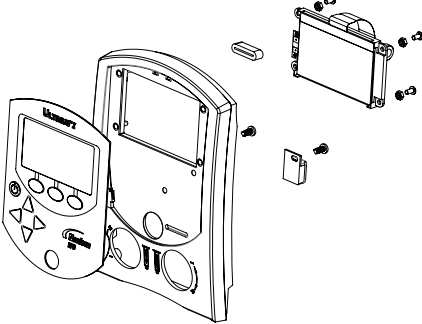
Replacement Parts (continued)

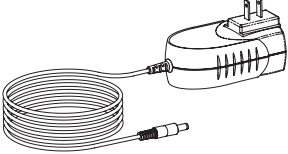
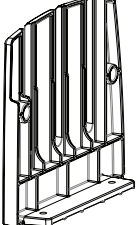
Item	Part #	Description
	7364470 (Ultimus I) 7364471 (Ultimus II)	Front panel
	7012274	Knob, vacuum or pressure regulator
	7002004	Tubing, 6 mm OD urethane, blue
	7015199	Universal power supply, 25W
	7017080	Work panel, right

Troubleshooting

If you encounter a problem that you cannot readily solve, call EFD.

Problem	Possible Cause and Corrective Action
No power	Be sure that there is AC power at the wall receptacle and that the blue LED on the power pack is on. Verify that the DC plug is securely connected to the Ultimus DC power input port.
Inconsistent dots	<ul style="list-style-type: none"> • Check dispensing tip, syringe barrel, and material for possible clogging. • Check the dispenser air pressure display to be sure air pressure is not varying. If needed, use the filter regulator. For dispenser accessories, refer to “Accessories” on page 28. • Air bubbles in the material can cause inconsistency. For best results, remove all air bubbles.
Timer seems inoperative	Check to be sure you are not in STEADY mode. The upper left corner of the display should read TIMED or MEMORY.
Material suck-back	<p>Try the following:</p> <ul style="list-style-type: none"> • Use a SmoothFlow piston or LV Barrier to prevent material being drawn into the dispenser. • Attach an empty barrel, put the unit in STEADY mode, place the barrel in a cup, and then press the foot pedal to expel the fluid. • Order the vacuum suck-back filter trap accessory, which is guaranteed to prevent fluid from leaking into the dispenser. For dispenser accessories, refer to “Accessories” on page 28. <p>If the problem cannot be corrected, contact an EFD Fluid Application Specialist for assistance.</p>
Display backlight intensity is low	The Ultimus workstation is in sleep / power save mode. Press any button or press the foot pedal to reactivate.
Voltage initiate does not function	Verify that the applied signal to pins 1 and 2 of the Ultimus I/O connector is between 5 and 24 VDC.
Air leaking from exhaust port	Air from the exhaust is normal when vacuum is used. If vacuum is completely off and you still exhaust hear air, make sure plant air supply to your unit is set to within 5.5–7.0 bar (80–100 psi).

NORDSON EFD FIVE⁽¹⁾ YEAR NO-FAULT WARRANTY

This Nordson EFD product is warranted for five⁽¹⁾ years from the date of purchase to be free from defects in material and workmanship (but not against damage caused by misuse, abrasion, corrosion, negligence, accident, faulty installation, or by dispensing material incompatible with equipment) when the equipment is installed and operated in accordance with factory recommendations and instructions.

Nordson EFD will repair or replace free of charge any defective part, regardless of fault, upon authorized return of the part prepaid to our factory during the warranty period. The only exceptions are those parts which normally wear and must be replaced routinely, such as, but not limited to, valve diaphragms, seals, valve heads, needles, and nozzles.

In no event shall any liability or obligation of Nordson EFD arising from this warranty exceed the purchase price of the equipment.

Before operation, the user shall determine the suitability of this product for its intended use, and the user assumes all risk and liability whatsoever in connection therewith. Nordson EFD makes no warranty of merchantability or fitness for a particular purpose. In no event shall Nordson EFD be liable for incidental or consequential damages.

This warranty is valid only when oil-free, clean, dry, filtered air is used, where applicable.

⁽¹⁾Two years for end users in Asia



For Nordson EFD sales and service in over 40 countries, contact Nordson EFD or go to www.nordsonefd.com.

Global

800-556-3484; +1-401-431-7000
info@nordsonefd.com

Europe

00800 7001 7001
infoefd.europe@nordsonefd.com

Asia

China: +86 (21) 3866 9006; china@nordsonefd.com
India: +91 80 4021 3600; india@nordsonefd.com
Japan: +81 03 5762 2760; japan@nordsonefd.com
Korea: +82-31-736-8321; korea@nordsonefd.com
SEAsia: +65 6796 9522; sin-mal@nordsonefd.com

The Wave Design is a trademark of Nordson Corporation.
©2024 Nordson Corporation 7028811 v050424