

# Advances in X-ray Tube Technology

By Igmar Grewar and Keith Bryant

## Closed or Sealed X-ray Tube

Early x-ray systems used within the electronics industry had a 'closed' or 'sealed' x-ray tube. Some current, low cost systems still use this technology. It was a 'fit and forget' item with the tube sealed for life. This was good from a maintenance view but as the x-ray target cannot be rotated or changed the image quality deteriorated throughout its life. The location of the x-ray focal spot relative to the closest position that a sample could be placed to the tube also severely limits the magnification that such an x-ray system could have. This can be an issue as electronic components continue to shrink in size. The limited x-ray cone angle of this tube type, i.e. the spread of its x-ray emission, also means that angled views are not possible without rotating the sample, which reduces the magnification still further, and / or rotating the tube. In addition to this, replacement costs were very high and reliability was also an issue. Feature recognition, the ability to see small objects, was also very limited with 8 microns being very good for a new system and 20 microns typical.

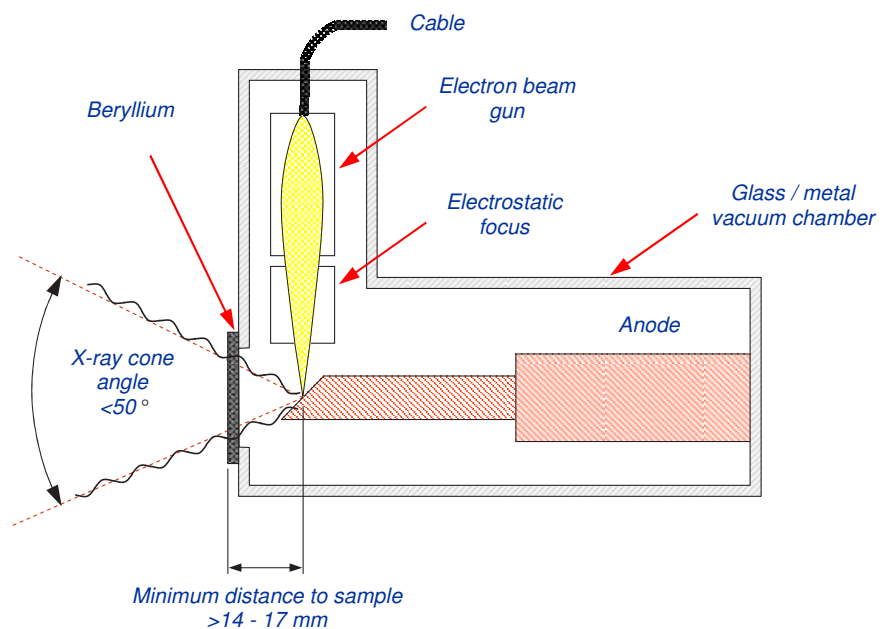

Figure 1 Closed X-ray Tube

# Advances in X-ray Tube Technology

By Igmarr Grewar and Keith Bryant

## Open X-ray Tube

The 'open' x-ray tube was a major step forward for x-ray inspection. It allows higher magnifications to be achieved because the focal spot can be much closer to the sample. Angled inspection views, so vital for joint inspection (especially for BGAs), can be achieved without loss of magnification, owing to the large x-ray cone angle, and with the target can be indexed or replaced. In addition, the feature recognition reduced to around 2 microns. Unlike the earlier systems, this technology requires a vacuum to be made continuously within the tube, hence the name 'open' tube, which means a turbo and roughing pump are running continuously to maintain the vacuum. The reason for this was the limited life of the filament producing the electron beam, in some systems this could mean as little as 100 hours of use before the filament failed and had to be replaced. From figure 2, it can be seen that because the filament is inside the tube, the vacuum has to be drained off, the tube split open, the broken filament assembly removed and a new one set up and fitted.

This procedure takes time and has several potential problem areas. Firstly, the tube has to be perfectly clean inside to prevent arcing potentially caused by the high voltages necessary to generate the x-rays. Secondly, a skilled engineer has to do the work and the vacuum takes time to recover. If the system is run at an insufficient vacuum level, or with contamination inside the tube, a huge stress is placed on the tube, which often leads to early failure of the filament or other components, requiring further tube maintenance with yet more opportunity for contamination etc... As the vacuum must be maintained 24/7 to prevent contaminants getting sucked back into the tube, any interruption in power supply or the machine being switched off can be a real problem. At best, it wastes time while the vacuum recovers, at worst it contaminates the tube. The limitation of producing the vacuum and potential issues with filament changes become more prominent in a production environment, where down time is to be reduced wherever possible.

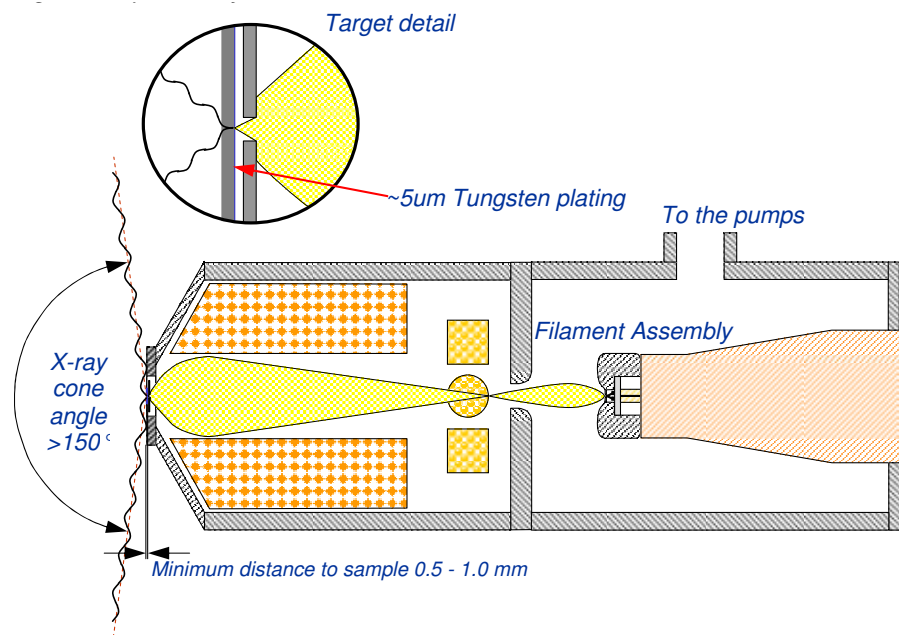

Figure 2 Open X-ray Tube

# Advances in X-ray Tube Technology

By Igmarr Grewar and Keith Bryant

## NT or Sealed Transmissive X-ray Tube

At the forefront of x-ray technology is the NT tube type, which is of the form 'sealed transmissive'. This offers all of the benefits, or better, of the previous tube types but without their downsides. It has a substantially longer 'fit and forget' lifetime at optimum resolution compared to a closed tube and it has better feature recognition than the very best open tube systems, all without the issues related to filament changes and continuously maintaining vacuum. This allows the NT tube to provide x-ray images with feature recognition down to 0.25 microns (250 nanometres). Unfortunately, due to issues with patents, it is not possible to show a cut through image of this tube type. It works using a patented, filament-free technology to generate the X-ray beam and the tube is factory sealed, working at a much higher vacuum level than open tubes can achieve. This is why it provides the 'fit and forget benefits' of the old closed tube system with image quality and feature recognition improvements even on the best open tube systems. Figure 3 below shows comparison images taken on both systems.

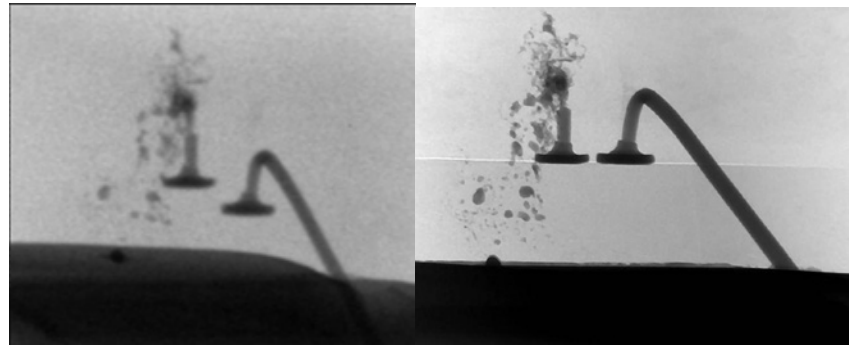

Figure 3 High resolution open tube image (left) and NT tube image (right)

## Conclusion

The patented NT tube technology offers major benefits to the user and no down side. Superior image quality combined with "fit and forget" capability, make it well suited to the production environment. The lack of maintenance and no worries about power interruptions make it ideal for remote locations. NT tubes have been in the field for over 4 years now and are proving to be extremely robust and reliable. Systems are currently in R and D which have feature resolution well beyond the requirement of electronics for the foreseeable future, demonstrating that the technology is "future proof".

For more information, speak with your Nordson representative or contact your Nordson Test & Inspection regional office

### Europe, SEA, Africa

ti-sales-eu@nordson.com

### China

ti-sales-cn@nordson.com

### Singapore

ti-sales-eu@nordson.com

### Korea

ti-sales-korea@nordson.com

### Americas

ti-sales-us@nordson.com

### Japan

ti-sales-jp@nordson.com

### Taiwan

ti-sales-tw@nordson.com