

396 1-Part No-Drip Series

One-component fluid control valves



Single ball and seat, piston actuated material valve

Valve data	
Dry weight	5.8 lbs. (2.63 kg)
Maximum inlet fluid pressure	5,000 PSI (344 bar)
Minimum inlet air pressure	60 PSI (4.2 bar)
Operation	Double air operated; air to open, air to close
Material delivery	Pressure tank, pressure pump
Viscosity range	Liquid to paste

Application solutions

- Aircraft and aerospace
- Appliance
- Battery
- Construction
- Electronics and electrical
- Filters
- Lighting and LED
- Solar and wind power



Benefits

- **Longer lifespan**
 - Wear-resistant seals and hardened components
 - Unrestricted internal design allows for the free flow of high viscosity materials
 - Divorced design separates fluid components from air components
- **Quality dispensing**
 - No-drip feature creates immediate material shut off
- **Exact consistency**
 - Short stroke length produces immediate on/off control of materials being dispensed

Features

- 1/2" NPT ports for higher material flow rates
- Hardened and ground spools
- Unique design allows for easy maintenance
- All stainless steel construction
- Multiple seal configurations are available

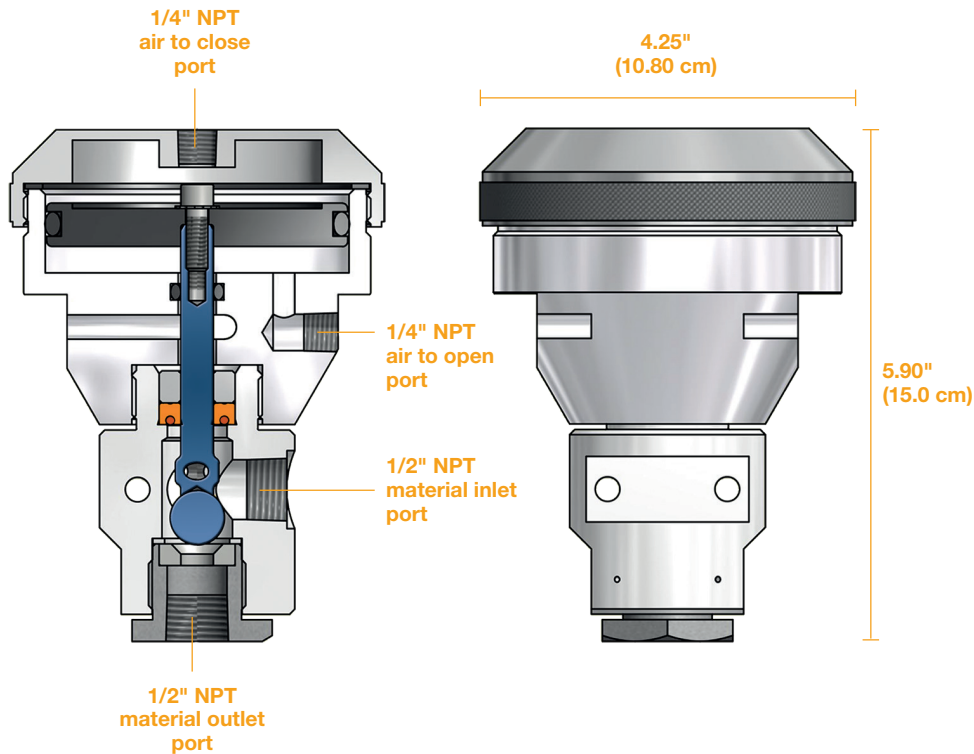

Frequently used models**	
7440098	Stainless steel and carbide with polymyte seals
7426154	Stainless steel and carbide with UHMW-PE seals
7425515	Stainless steel and carbide with UHMW-PE seals and heat cartridge capable

* Consult your Nordson representative with application specifics for accurate valve capabilities.

+ Many additional models and options are available.

© 2019 Nordson Corporation | All Rights Reserved | NSL-19-5964 | Revised 2/19

Nordson expertise is always here when you need it

In highly competitive manufacturing markets, productivity is vital and performance is essential. That's why we apply both to everything we do, whether it's our products, expertise or outstanding customer service. We'll always be there to help maintain the new standards you've set, with expert local service and support delivered through our teams working across the globe.

This unique Nordson approach helps you reach new levels of production, while working more accurately, efficiently and competitively than ever. Precisely why manufacturers who demand quality, can rely on Nordson.

Performance by design

Nordson SEALANT EQUIPMENT

Nordson Sealant Equipment
Wixom, MI, USA

Phone: 1.248.412.7920

Email: SealantSales@nordson.com

[Twitter](#) /Nordson_Coating [YouTube](#) /SealantEquipment

[LinkedIn](#) /company/nordson-industrial-coating-systems

Find out more at:

www.nordson.com/nse

