

# EDI® Autoflex™ Technology

**Ensure unsurpassed product quality and performance when you partner with the industry's leader in flat die manufacturing and technology.**

## Benefits of Autoflex™ Technology

- Reduce gauge variation and increase product yield when paired with processor based gauging system
- Eliminate heat transfer between die body, lip, and translator block with heating unit isolated above the flexible lip die body
- Reduce operational adjustments with automatic mode allowing for more linear movement
- Achieve a balanced and repeated fast response with air cooling ported to each translator
- Fine manual tuning is possible with differential adjustment system

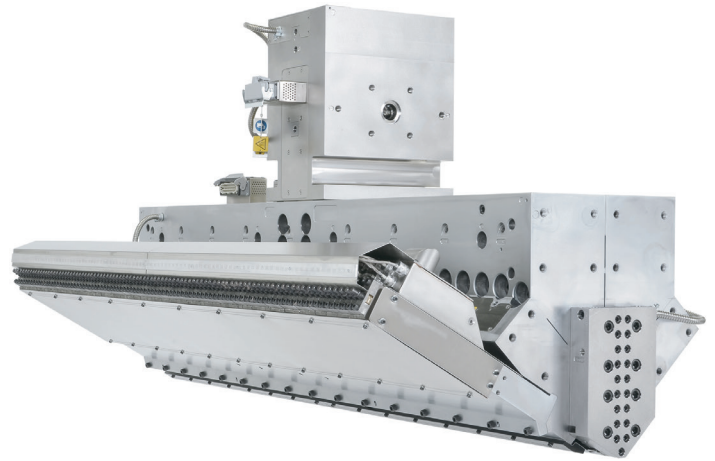

*1950mm (77") Autoflex VI-R H100 Triple Manifold Die & 3 Layer Distribution Block*

The Autoflex system uses thermal expansion and contraction of the lip adjusting unit to make finer adjustments to the flexible lip than are possible with strictly mechanical means.

Each lip adjusting position is fitted with a block containing a heater and an air cooling path. Inherent in the system is complete manual override, so that the approximate gauge uniformity is established in the conventional manner before the thermal system is engaged. The thermal adjusting system utilizes an electrical source for each adjusting point to increase or decrease the temperature of the adjusting block, thereby changing the lip opening.

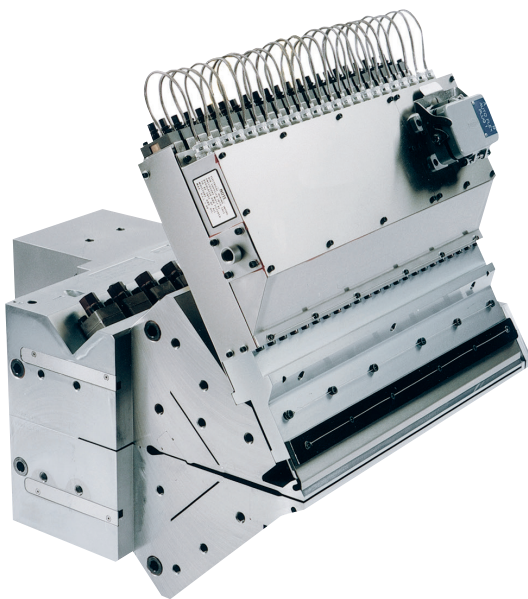

*660mm (26") Autoflex VI-R H40 Triple Manifold Die & Distribution Block*

## Autoflex™ Design Features

- Low mass translators, which provide improved reaction time for both heating and cooling cycles
- Adjustments available on 21.0mm (0.827"), 25.4mm (1.000"), or 28.6mm (1.125") centers; additional spacing options available on request
- Stainless steel cover installed over adjustment system, preventing external drafts from influencing the adjustments and vapor residue from building up on adjusting components.
- Low profile, close approach to nip
- Parts that use working threads are replaceable
- Manual adjusting system can be provided with differential push/pull option
- Optional feature allows for system to be removed as a complete modular assembly

# EDI® Autoflex™ Technology

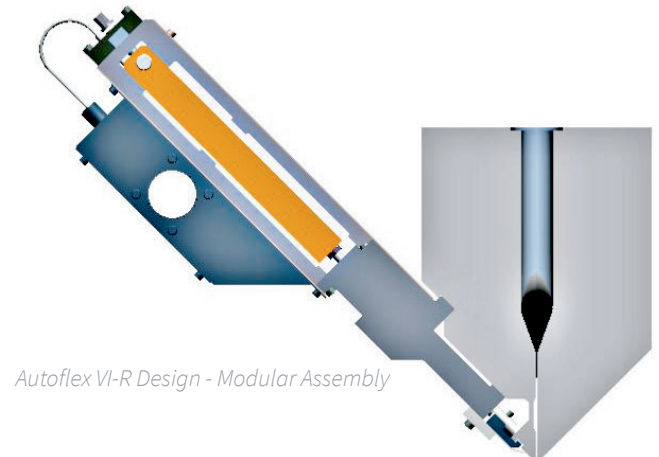
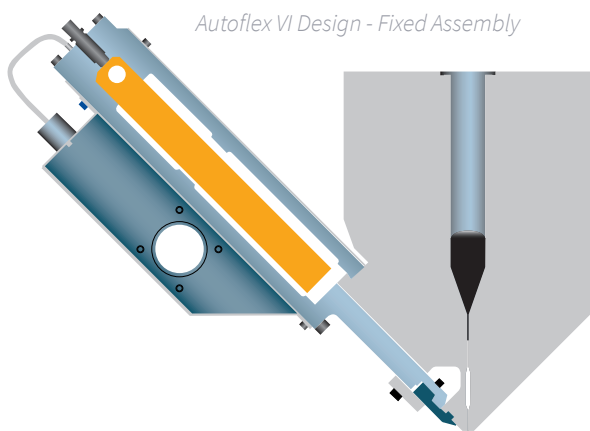

Installed on thousands of dies worldwide, the Autoflex automatic lip adjusting system is the premier technology for precisely controlling the thickness profile of the film and sheet. In addition to making possible higher quality, more accurate products, the Autoflex system can generate substantial raw material savings compared to conventional manual adjustment.

The simplicity of design and proven accuracy in production in the field makes Autoflex the world's preferred automatic die bolt control system.

## Autoflex™ VI-RE: Achieving a Broader Scope of Automation

*US Patent 10,518,459*

- Provides a 43% increase in stroke of the lip adjusting system without adding to response time, enabling the system to correct a wider range of process variations, often without need of manual intervention
- Autoflex VI-RE system may be operated in convective or forced air cooling conditions
- Reduce downtime with an Autoflex designed to provide easy access to wearable parts during routine maintenance and cleaning
- Heater wiring is routed directly into a junction box via a quick disconnect plug
- Features module sets, containing 3 or 4 adjustments each, allowing for easy access to wearable parts in a specific area of the system
- Additional module sets may be purchased for a spare set to use while repairing the original component
- Retrofittable to existing dies

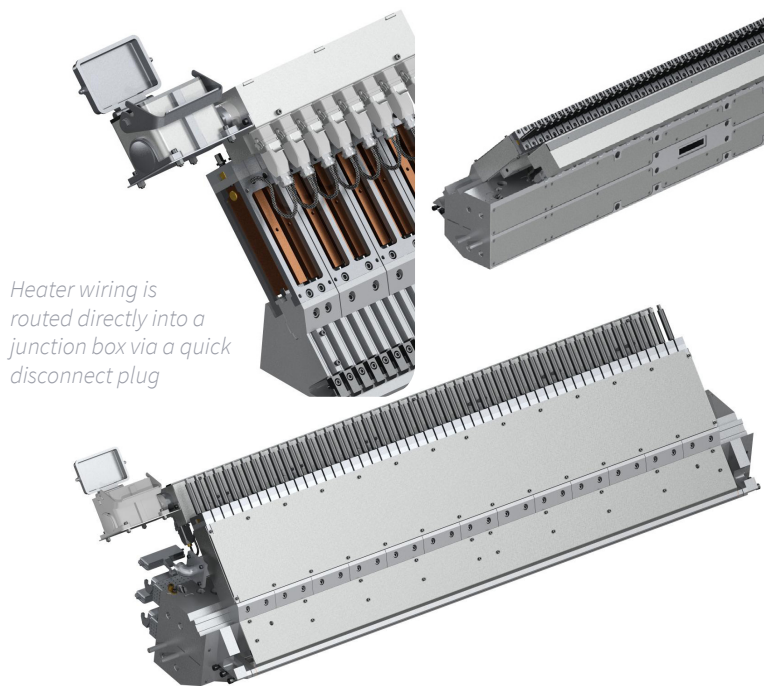

**Nordson Extrusion Dies Industries, LLC**  
1450 Lakeland Drive  
Chippewa Falls, WI 54729 USA  
Phone +1.715.726.1201

**Germany**  
Phone +49.251.26501.0

**China**  
Phone +86.21.5785.091.8

**Japan**  
Phone +81.3.5762.2770

