

7197PCP-DIN-NX Controller

Ethernet compatibility for Smart Factory integration



The 7197PCP-DIN-NX controller incorporates NX protocol via Ethernet for Smart Factory integration.

Part #	Description
7365704	7197PCP-DIN-NX controller

For 2K applications, two controllers are required.

The network capable 7197PCP-DIN-NX controller provides precise control of volumetric dispensing parameters for 797PCP and 797PCP-2K Series progressive cavity pumps. It allows direct communication with a Programmable Logic Controller (PLC) or other manufacturing plant controllers using the NX protocol (network connectivity) via Ethernet.

This technology enhancement allows operators to control all dispensing parameters directly from a PLC or computer, giving the operator complete remote control of our 797PCP volumetric dispensing pumps.

Through a PLC and monitor screen, record and download process feedback based on chosen dispense parameters to improve process control.

The 7197PCP-DIN-NX controller's small form factor is designed for mounting on a DIN rail inside a machine cabinet, allowing more working space on an automated production line.

Features

- Ethernet control with NX protocol
- Communication between PLC and DIN controller
- Line, Volume, Weight, and Timed dispense modes for a wide range of dispensing applications
- Nordson NX Client Application included, Windows-based graphical user interface (GUI)

Benefits

- Improve operational efficiency by programming 797PCP pumps directly from a central PLC
- Save time by updating multiple controllers from a centralized location
- Support Smart Factory integration using Ethernet compatibility with NX protocol
- Verify rotor movement with encoder count feedback
- Nordson NX Client Application software offers in-place troubleshooting capabilities and simplifies implementation of the NX protocol



more info



Specifications

Item	Specification
Cabinet size	3.2W × 9.4H × 14.6D cm (1.27W × 3.70H × 5.75D")
Weight	0.7 kg (1.5 lb)
Rotor speed	10–150 RPM
Time range	0.001–600,000 ms (1 s to 10 min)
Electrical power input	24 VDC (± 2%), 3.75 Amp maximum
Feedback circuits	Electronic switch, 24 VDC, 100 mA maximum
Initiate circuits	24 VDC signal
Approvals	CE, UKCA, TUV, RoHS, China RoHS, WEEE
Warranty	1 year, limited

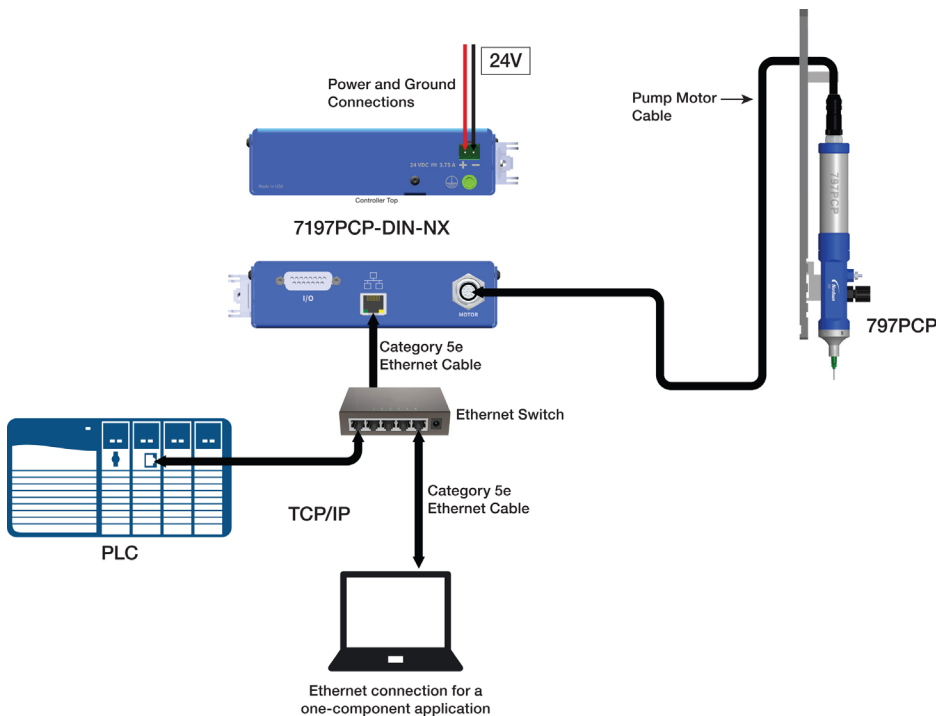

797PCP Series Progressive Cavity Pumps

Nordson EFD progressive cavity pumps deliver reliable volumetric dispensing. Our 797PCP Series pumps provide industry-leading repeatability at $\pm 1\%$ when dispensing one-component or two-component (2K) fluids.



EFD

For Nordson EFD sales and service in over 40 countries, contact Nordson EFD or go to www.nordsonefd.com.

Global

800-556-3484; +1-401-431-7000
info@nordsonefd.com

Europe

00800 7001 7001
infoefd.europe@nordsonefd.com

Asia

China: +86 (21) 3866 9006; china@nordsonefd.com
 India: +91 80 4021 3600; india@nordsonefd.com
 Japan: +81 03 5762 2760; japan@nordsonefd.com
 Korea: +82-31-736-8321; korea@nordsonefd.com
 SEAsia: +65 6796 9522; sin-mal@nordsonefd.com

©2024 Nordson Corporation v111224